

BEST PRACTICES:

Monitoring, Verification, and Accounting (MVA) for Geologic Storage Projects

2017 REVISED EDITION

DOE/NETL-2017/1847

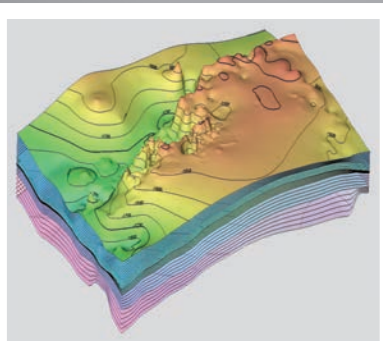

NETL

NATIONAL ENERGY TECHNOLOGY LABORATORY



BEST PRACTICES

DISCLAIMER

This report was prepared as an account of work sponsored by an agency of the United States Government. Neither the United States Government nor any agency thereof, nor any of their employees, makes any warranty, express or implied, or assumes any legal liability or responsibility for the accuracy, completeness, or usefulness of any information, apparatus, product, or process disclosed, or represents that its use would not infringe privately owned rights. Reference therein to any specific commercial product, process, or service by trade name, trademark, manufacturer, or otherwise does not necessarily constitute or imply its endorsement, recommendation, or favoring by the United States Government or any agency thereof. The views and opinions of authors expressed therein do not necessarily state or reflect those of the United States Government or any agency thereof.

BEST PRACTICES:

Monitoring, Verification, and Accounting (MVA) for Geologic Storage Projects

DOE/NETL-2017/1847

August 2017

National Energy Technology Laboratory

www.netl.doe.gov

TABLE OF CONTENTS

Acronyms and Abbreviations	8
Terminology	10
Executive Summary	12
1.0 Introduction	14
2.0 Monitoring, Verification, and Accounting Plan Development	18
2.1 Risk-Based Monitoring Strategies	18
2.1.1 Workflow for Developing Site-Specific MVA Plans	19
2.1.2 Examples of Risk-Based MVA Plan Workflows	20
2.2 RCSP Case Study	23
3.0 CO₂ Monitoring Techniques	24
3.1 Atmospheric Monitoring	24
3.1.1 Regulatory Requirements	24
3.1.2 Atmospheric Baselines	25
3.1.3 Atmospheric Tools and Approaches	26
3.2 Near-Surface Monitoring	32
3.2.1 Regulatory Requirements	33
3.2.2 Near-Surface Baselines	33
3.2.3 Near-Surface Tools and Approaches	34
3.3 Subsurface Monitoring	45
3.3.1 Regulatory Requirements	45
3.3.2 Subsurface Tools and Approaches	46
3.4 RCSP Case Studies	64
4.0 Summary	74
Appendix 1—RCSP Initiative	75
References	76
Acknowledgments	86
Contacts	87

LIST OF FIGURES

Figure 1: Locations of RCSP Large-Scale Development Phase Projects	16
Figure 2: Iterative MVA and Risk Analysis; Adapted from Det Norske Veritas	18
Figure 3: Workflow for the Preparation of a Risk-Based MVA Plan	19
Figure 4: Shell QUEST CCUS Project Cost-Benefit Ranking of Monitoring Technologies	20
Figure 5: Plotted Severity and Likelihood Risk Coordinates for Each of 119 FEPs	21
Figure 6: Conceptual Diagram of Atmospheric, Near-surface, and Subsurface Monitoring of Carbon Storage Operations.	25
Figure 7: Hourly Averaged Concentration Measurements of CO ₂ , CH ₄ , and H ₂ O from July 2010 to December 2012, Taken at Arcturus GHG Monitoring Station Near Emerald, Queensland, Australia.	26
Figure 8: MTRS and WVS Systems for Atmospheric PFT Tracer Monitoring	30
Figure 9: Map of Log Soil CO ₂ Flux, Interpolated Based on Measurements Made at the Black Dots on July 25, 2008	31
Figure 10: Near-Surface Monitoring in Relation to Other Subsurface Monitoring Techniques	32
Figure 11: Schematic of 1 x 4 Fiber Sensor Array for Soil-CO ₂ Detection	37
Figure 12: Groundwater pH, Alkalinity, and Electrical Conductance Values Measured at the ZERT Site; Monitoring Well Configuration is Also Shown	40
Figure 13: Schematic of LIBS.	41
Figure 14: Satellite Image of Cumulative Surface Deformation at Krechba (In Salah) Due to CO ₂ Injection	43
Figure 15: Schematic of Reservoir and Overburden Deformation for Conservative Scenario	44
Figure 16: Aerial Hyperspectral Imagery Collected at the ZERT Facility 27 Days After CO ₂ Injection, 2008	45

Figure 17: A pulsed-neutron well log displaying facies, gamma ray, baseline sediment and fluid (water/oil) composition, measured depth, resistivity, perforation interval and porosity; water, oil, and CO₂ saturation logs. 50

Figure 18: PNC Log Results Exhibits Increase in Gas Saturation, Attributed to Increased Presence of CO₂ 51

Figure 19: U-Tube Downhole Assembly Detail 53

Figure 20: Schematics of Various Seismic Monitoring Techniques 56

Figure 21: Time-Lapse Seismic Difference Amplitude Maps at Sleipner 57

Figure 22. Pixelized difference tomography results without seismic reflection overlay showing positive velocity differences in yellow and negative differences in green and blue (SECARB Citronelle Project). 59

Figure 23: Map of Observed Gravity Changes at Sleipner (2002-2009), Indicating Lowered Gravity Due to CO₂ 61

Figure 24: Crosswell Configuration and Time-Lapse Monitoring Results, Indicating Absolute Resistivity Distribution Along Two Observation Wells and Changes in Resistivity Over Base Data at Ketzin 63

LIST OF TABLES

Table 1: RCSP Large-Scale Development Phase Projects	17
Table 2: Risk-Related FEPs	22
Table 3: Summary of Atmospheric Monitoring Techniques.	27
Table 4: Summary of Near-Surface Monitoring Techniques	35
Table 5: Summary of Subsurface Monitoring Techniques.	46

ACRONYMS AND ABBREVIATIONS

Acronym/ Abbreviation	Definition
¹⁴ C	Carbon-14
AoR	Area of Review
ASTM	American Society of Testing and Materials
BPM	Best Practice Manual
BSCSP	Big Sky Carbon Sequestration Partnership
C/O	Carbon/Oxygen Ratio
C ₂ H ₄	Ethylene
C ₂ H ₆	Ethane
Ca	Calcium
CASSM	Continuous Active Source Seismic Monitoring
CCS	Carbon Capture and Storage
CH ₄	Methane
CO	Carbon Monoxide
CO ₂	Carbon Dioxide
CO2CRC	Cooperative Research Centre for Greenhouse Gas Technologies
CODDA	Carbon Dioxide Detection by Differential Absorption
CRDS	Cavity Ring-Down Spectroscopy
CSA	Canadian Standards Association
CSEM	Controlled-Source Electromagnetic
CT	Computed Tomography
DAS	Distributed Acoustic Sensing
DFB	Distributed Feedback
DIC	Dissolved Inorganic Carbon
DOE	U.S. Department of Energy
DTPS	Distributed Thermal Perturbation Sensor
DTS	Distributed Temperature Sensor
EC	Eddy Covariance
EERC	Energy & Environmental Research Center of the University of North Dakota
EGR	Enhanced Gas Recovery

Acronym/ Abbreviation	Definition
EM	Electromagnetic
EOR	Enhanced Oil Recovery
EPA	U.S. Environmental Protection Agency
ERT	Electrical Resistance Tomography
ET	Electrical Tomography
Fe	Iron
FE	Office of Fossil Energy
FEP	Features, Elements, or Processes
FMEA	Failure-Mode-and-Effects Analysis
FMS	Frequency-Modulated Spectroscopy
FWU	Farnsworth Unit
GC	Gas Chromatography
GC-ECD	Gas Chromatography – Electron Capture Detector
GHG	Greenhouse Gas
GLONASS	Russian Global Navigation Satellite System
GNSS	Global Navigation Satellite System
GPS	Global Position System
GS	Geologic Storage
H&S	Health and Safety
H ₂	Hydrogen
H ₂ S	Hydrogen Sulfide
He	Helium
IBDP	Illinois Basin Decatur Project
IEA	International Energy Agency
IEAGHG	International Energy Agency Greenhouse Gas Research and Development Program
InSAR	Interferometric Synthetic Aperture Radar
IPAC-CO ₂	International Performance Assessment Center for Geologic Storage of Carbon Dioxide
IPCC	Intergovernmental Panel on Climate Change

Acronym/ Abbreviation	Definition
IR	Infrared
IRGA	Infrared Gas Analyzer
ISO	International Organization for Standardization
L&S	Likelihood and Severity
LAS	Laser Absorption Spectrometer
LIBS	Laser-Induced Breakdown Spectroscopy
LIDAR	Light Detection and Ranging
MASW	Multichannel Analysis of Surface Waves
MBM	Modular Borehole Monitoring
Mg	Magnesium
MGSC	Midwest Geological Sequestration Consortium
MIT	Mechanical Integrity Test
Mn	Manganese
MRCSP	Midwest Regional Carbon Sequestration Partnership
MRV	Monitoring, Reporting, and Verification
MSU	Montana State University
MTRS	Multi-Tube Remote Sampler
MVA	Monitoring, Verification, and Accounting
N ₂	Nitrogen
NDIR	Non-Dispersive Infrared
NETL	National Energy Technology Laboratory
O ₂	Oxygen
OSU	Oklahoma State University
PCOR	Plains CO ₂ Reduction Partnership
PFT	Perfluorocarbon Tracer
PIDAS	Pressure-Based Inversion and Data Assimilation System
PNC	Pulsed Neutron Capture

Acronym/ Abbreviation	Definition
PNL	Pulsed Neutron Logging
PNT	Pulsed Neutron Tools
ppm	Parts Per Million
psi	Pounds Per Square Inch
PSInSAR	Permanent Scatterer Interferometric Synthetic Aperture Radar
R&D	Research and Development
RCSP	Regional Carbon Sequestration Partnership
RISCS	Research Into Impacts and Safety in CO ₂ Storage
RITE	Research Institute of Innovative Technology for the Earth
RST	Reservoir Saturation Tool
S/N	Signal-to-Noise Ratio
SACROC	Scurry Area Canyon Reef Operators Committee
SECARB	Southeast Regional Carbon Sequestration Partnership
SF ₅ CF ₃	Trifluoromethyl Sulphur Pentafluoride
SF ₆	Sulfur Hexafluoride
STM	Surface Tilt Monitoring
SWP	Southwest Regional Partnership on Carbon Sequestration
tpd	Tonnes Per Day
UAV	Unmanned Aerial Vehicle
UIC	Underground Injection Control Program
USDW	Underground Sources of Drinking Water
VC	Volumetric Curvature
VERA	Vertical Electrical Resistivity Array
VOC	Volatile Organic Compound
VSP	Vertical Seismic Profile
WVS	Wind-Vane Sampler
ZERT	Zero Emission Research and Technology Center

TERMINOLOGY

Area of Review: The region around an injection well which may be endangered by the injection activity. This endangerment could come from either the increased pressure in the storage reservoir, or the presence of CO₂.

Atmospheric Monitoring: Testing at the surface and in the atmosphere to identify and quantify possible releases associated with carbon storage operations.

Caprock: A low-permeability sedimentary layer, which immediately overlies the reservoir and serves as a physical barrier to upward migration of CO₂ or brine from the top of the reservoir.

Confining Zone: One or more geologic barriers, typically low-permeability rock units that overlie or enclose a storage reservoir and are capable of preventing upward and/or lateral migration of CO₂ or brine out of the reservoir. A confining zone may contain multiple geologic seals.

Geologic Seal: A low-permeability sedimentary or structural unit, such as shale or a sealing fault, which provides a physical barrier to upward or lateral migration of CO₂ or brine out of the reservoir.

Injection Interval: The perforated interval through which CO₂ injectate is pumped into the storage reservoir.

Injection Zone: Specific sedimentary layers, within a storage reservoir, that are targeted for current or future CO₂ injection.

Near-Surface Monitoring: Testing in the vadose zone and groundwater sources to identify and quantify possible releases associated with carbon storage operations.

Pore Space: The void space in formation rocks that can contain fluids

Potential Site: A specific project site that has potential capacity, injectivity and containment for CO₂ storage but requires more data acquisition and further evaluation to be defined as Qualified Site.

Potential Sub-Region: A project region associated with a sub-regional trend of potential CO₂ storage sites, but which requires more data acquisition and/or evaluation to define Selected Areas.

Qualified Site: A project site that has met all required technical and non-technical criteria for CO₂ storage and is ready to permit.

Selected Area: A project area that shows sufficient capacity, injectivity and containment for CO₂ storage but is currently poorly defined and requires more data acquisition and further evaluation to be defined as Qualified Site.

Site Characterization: The process of evaluating Potential Sites to identify one or more "Qualified Sites" which are viable for storage and ready to permit. Technical and non-technical data is used and data sampling/analysis is site-specific. Site Characterization involves two stages: (1) Initial Characterization involves analysis of available site-specific information and (2) Detailed Characterization involves site-specific field acquisition and analysis of new data.

Site Screening: The process of evaluating Sub-Regions within basins or other large geographic regions and identifying “Selected Areas” within those regions which warrant additional investigation for storage. Available technical and non-technical data is used and data sampling / analysis is coarse.

Site Selection: The process of evaluating Selected Areas and identifying “Potential Sites” within those areas, which warrant additional investigation for storage. Available technical and non-technical data is used and data sampling/analysis is necessary and sufficient to identify individual sites.

Storage Complex: A geologic entity that is physically suitable for long-term storage of CO₂. It consists of: (1) one or more storage reservoirs, with permeability and porosity that allow injection and storage of CO₂; and (2) one or more low-permeability seals, which enclose the reservoir(s) and serve as barriers to migration of CO₂ out of the reservoir units.

Storage Formation: An established, named geologic formation that contains known or potential CO₂ storage reservoirs.

Storage Reservoir: Layers of porous and permeable rock, within a geologic formation, which are confined by impermeable rock, characterized by a single pressure system, and suitable for long-term storage of CO₂.

Subsurface Monitoring: Testing to locate CO₂ in the target and surrounding storage formations.

Area of Review: The region around an injection well which may be endangered by the injection activity. This endangerment could come from either the increased pressure in the storage reservoir, or the presence of CO₂.

EXECUTIVE SUMMARY

Geologic storage of anthropogenic CO₂ has gained recognition in recent years as a promising strategy for reducing greenhouse gas emissions. In accordance with this, the U.S. Department of Energy (DOE) National Energy Technology Laboratory (NETL) is developing technologies that will enable widespread commercial deployment of geologic storage of CO₂ by 2025-2035.

DOE has engaged with technical experts in the Regional Carbon Sequestration Partnership (RCSP) Initiative to update its Best Practice Manuals (BPMs) for geologic storage projects. The BPMs are intended to disseminate knowledge gained through the RCSP Initiative and to establish uniform approaches for carrying out successful projects.

The first editions of the BPMs were completed between 2009 and 2013 and incorporated findings from RCSP Characterization Phase and small-scale Validation Phase field projects. The 2017 Revised Editions of the BPMs include lessons learned in more recent years, as the RCSPs have progressed to large-scale Development Phase field projects.

The five 2017 Revised Edition BPMs are:

- BEST PRACTICES: Site Screening, Site Selection, and Site Characterization for Geologic Storage Projects
- BEST PRACTICES: Public Outreach and Education for Geologic Storage Projects
- BEST PRACTICES: Risk Management and Simulation for Geologic Storage Projects
- BEST PRACTICES: Operations for Geologic Storage Projects
- BEST PRACTICES: Monitoring, Verification, and Accounting (MVA) for Geologic Storage Projects

The BPMs are interconnected, and together they are intended to provide a holistic approach to carrying out a geologic storage project, from inception to completion.

This manual discusses development of risk-based MVA plans for geologic carbon storage projects, and provides recent research results concerning existing and emerging MVA techniques. Although the focus is on the experience gained through the DOE RCSP Initiative, MVA plans and a few key monitoring techniques applied at international large-scale field projects are described. Best practices result from successful application of techniques during field application and are documented through lessons learned. Technical references are provided for readers interested in further information. Current and ongoing research focused on emerging tools is provided as well.

A wide variety of tools and techniques are available for monitoring CO₂ stored in deep subsurface geologic storage sites, as well as conducting surveillance to assure that unlikely but potential release from storage is not occurring. Techniques are described for use in the atmosphere, in the near-surface region, and in the subsurface.

The most common atmospheric monitoring techniques are optical CO₂ sensors, atmospheric tracers, and eddy covariance flux measurements. Near-surface monitoring techniques include geochemical monitoring in the soil and vadose zone, geochemical monitoring of near-surface groundwater, surface displacement monitoring, and ecosystem stress monitoring. The purpose of these near-surface monitoring approaches is to detect manifestations of CO₂ potentially released from storage. Subsurface monitoring of CO₂ storage projects includes monitoring the evolution of the dense-phase CO₂ plume, assessing the area of elevated pressure caused by injection, and measuring to determine that both pressure and CO₂ are within the expected and acceptable areas and migrating in a way that does not damage resources or the integrity of the storage. Subsurface monitoring is carried out using an extensive range of techniques. Some techniques access the subsurface via wells and can probe an area around the well in high resolution; other techniques are deployed at the surface and use geophysical properties to measure fluid and rock properties at a distance, and combined instruments deployed such as using two or more wells or one well and the surface can be used.

The primary audience for this best practice manual (BPM) is future storage project developers. It will also be useful for informing local, regional, state, and national governmental agencies about best practices for monitoring CO₂ geologic storage sites. Furthermore, it will inform the general public about the risk-based analysis used to develop the site monitoring plan and the variety of techniques that are considered to carry out the plan.

The manual is not intended as a guide to comply with regulations, nor is it meant to identify a subset of techniques that should always be part of a site monitoring plan. Each technique has its benefits and its challenges and the project developer must determine the appropriate set of techniques needed to meet the objectives of their site-specific monitoring plan. Some of the lessons learned for a identify challenges that limit a techniques use or require additional research.

Finally, this BPM is a revision to the 2013 edition. In addition to updating the contents to reflect the current state-of-knowledge and extensive experiences of the RCSPs, it is also an enhancement because it contains lessons learned and case studies that are specific to the RCSPs and select international field projects.

1.0 INTRODUCTION

Geologic storage of anthropogenic CO₂ has gained recognition in recent years as a promising strategy for reducing greenhouse gas emissions from industrial sources. In accordance with this, the overall objective of the U.S. Department of Energy (DOE) National Energy Technology Laboratory (NETL) Carbon Storage Program is to develop technologies that will enable widespread commercial deployment of safe and permanent geologic storage of CO₂ by 2025-2035.

As an important step in meeting this objective, DOE/NETL established the Regional Carbon Sequestration Partnership (RCSP) Initiative (see Appendix I). This national Initiative, launched in 2003, includes seven regional partnerships tasked with developing and testing technologies and approaches for safe and permanent storage of CO₂ in different geologic and geographic settings across the United States. An important outcome of the RCSP Initiative is the publication of a series of topical BPMs for geologic storage projects. The BPMs are intended to disseminate knowledge gained through the RCSP field efforts and to establish effective methods, reliable approaches, and consistent standards for carrying out successful geologic storage projects.

The first editions of the BPMs were completed between 2009 and 2013 and presented salient findings of the RCSP's Characterization and Validation Phase field projects. Since that time, the RCSPs have progressed to large-scale Development Phase field projects. For the 2017 Revised Editions of the BPMs, DOE/NETL has worked closely with technical experts from the RCSPs to incorporate new findings and lessons learned from these Development Phase projects.

The five 2017 Revised Edition BPMs are:

- BEST PRACTICES: Site Screening, Site Selection, and Site Characterization for Geologic Storage Projects
- BEST PRACTICES: Public Outreach and Education for Geologic Storage Projects
- BEST PRACTICES: Risk Management and Simulation for Geologic Storage Projects
- BEST PRACTICES: Operations for Geologic Storage Projects
- BEST PRACTICES: Monitoring, Verification, and Accounting (MVA) for Geologic Storage Projects

Taken separately, each BPM can serve as a stand-alone guide for conducting specific activities related to Characterization, Public Outreach, Risk Management, Operations, or MVA. Taken together, the five BPMs are interconnected—each linked to the others by the interdisciplinary nature of a geologic storage project. They are intended to provide a holistic approach to carrying out a multifaceted geologic storage project, from inception to completion.

The 2017 Revised Edition BPM on “Monitoring, Verification, and Accounting (MVA) for Geologic Storage Projects” is a revision of an earlier version, published in 2013. It includes descriptions of applicable MVA techniques, related regulatory requirements, and lessons learned from recent field trials of various MVA tools and approaches.

This BPM is a technical guide to monitoring, verification, and accounting (MVA) of CO₂ stored in geologic formations. The information compiled here is intended to increase awareness of existing and emerging MVA techniques and, ultimately, to help ensure safe and permanent geologic storage CO₂. The target audience for this BPM includes project developers, regulatory officials, national and state policymakers, and the general public.

The MVA plan for a given storage project will have a broad scope, covering CO₂ storage containment, internal quality control, and verification and accounting for regulators and monetizing benefits of geologic storage. MVA programs need to be flexible and site-specific to adapt to the inherent variability and heterogeneity of geologic systems. MVA plans also tend to change in scope as a project progresses from the pre-injection phase to the post-injection phase. For all these reasons, MVA plans need to be tailored to site-specific geologic conditions and operational considerations. For example, some monitoring techniques are better suited to providing data specific to regulatory compliance, while other tools are better suited to reservoir management. Risk management plays an important role in the design of MVA plans, as well, and this role is detailed in Chapter 2.

MVA is an essential part of ensuring safe, effective, and permanent CO₂ storage in all types of geologic formations. Monitoring technologies can be deployed for atmospheric (surface and above), near-surface, and subsurface applications to ensure that injected CO₂ remains in the targeted formation and that injection wells and preexisting wells are not prone to unintended CO₂ release. Since

Federal and state GHG regulations and emission trading programs have been developed, monitoring has also gained importance as a means of accounting for the quantity of CO₂ that is injected and stored underground. The location of the injected CO₂ plume in the storage complex can also be inferred, via monitoring, to satisfy operating requirements under the Environmental Protection Agency's (EPA) Underground Injection Control (UIC) Class VI and GHG Reporting Programs to ensure that potable groundwater and ecosystems are protected. In fields where CO₂ storage goes hand-in-hand with enhanced oil recovery (EOR), monitoring may be easier in some situations as there would be a greater number of wells in place, allowing for tracking and sampling of CO₂. On the other hand, monitoring may also be more challenging because of the presence of oil and gas in the formation, adding complexity that needs to be considered in order to select monitoring methods that are best suited to fields where EOR is feasible. The portfolio of available monitoring technologies for all types of CO₂ storage situations is large and continues to grow. Chapter 3 provides an extensive discussion of existing and evolving monitoring tools, the information that each tool can provide, and the tool's R&D status. Chapter 3 also provides some insight on how some of these tools can be used to meet regulatory requirements.

Underground injection of CO₂ for purposes such as EOR is a long-standing practice. EPA Class II well regulations address injection of fluids for EOR and enhanced gas recovery (EGR) applications. Carbon dioxide injection specifically for geologic storage involves different technical issues and potentially much larger volumes of CO₂. The EPA Class VI rule builds on existing UIC Program requirements, with extensive tailored requirements that address CO₂ injection for long-term storage.

In December 2010, significant steps were made toward defining the regulatory framework for carbon capture and storage (CCS) in the United States when EPA released the aforementioned UIC Class VI and GHG Reporting rules (EPA, 2016a). The UIC Program regulates the injection of all fluids into the subsurface, and a UIC Class VI well rule was developed specifically for injection wells used for geologic storage of CO₂. These regulations were developed to protect underground sources of drinking water (USDWs) and to ensure that injection operations do not endanger USDWs or human health. Monitoring techniques that address well integrity, groundwater monitoring, subsurface plume tracking, long-term containment of the injected plume, and soil-gas and surface-air monitoring are all applicable to UIC Class VI Rule requirements. The monitoring tools described later in this document have been developed to support geologic storage operations but also address UIC Class VI Rule requirements. EPA used the data and experience from the Core R&D Initiative, international projects, and RCSP Initiative as a foundation for development of these regulations. Results from large- and small-scale geologic storage projects will continue to contribute to support future GHG registries, incentives, or other policy instruments that may be deemed necessary.

Throughout the manual, examples and lessons learned are provided as "case studies" from the RCSP Large-Scale Development Phase field projects. Figure 1 and Table 1 provide the fundamental information on these RCSP projects, including project name, project type, geologic basin, amount of stored CO₂, and geographic location. Some additional context for the RCSP Development Phase field projects is provided in Appendix I.

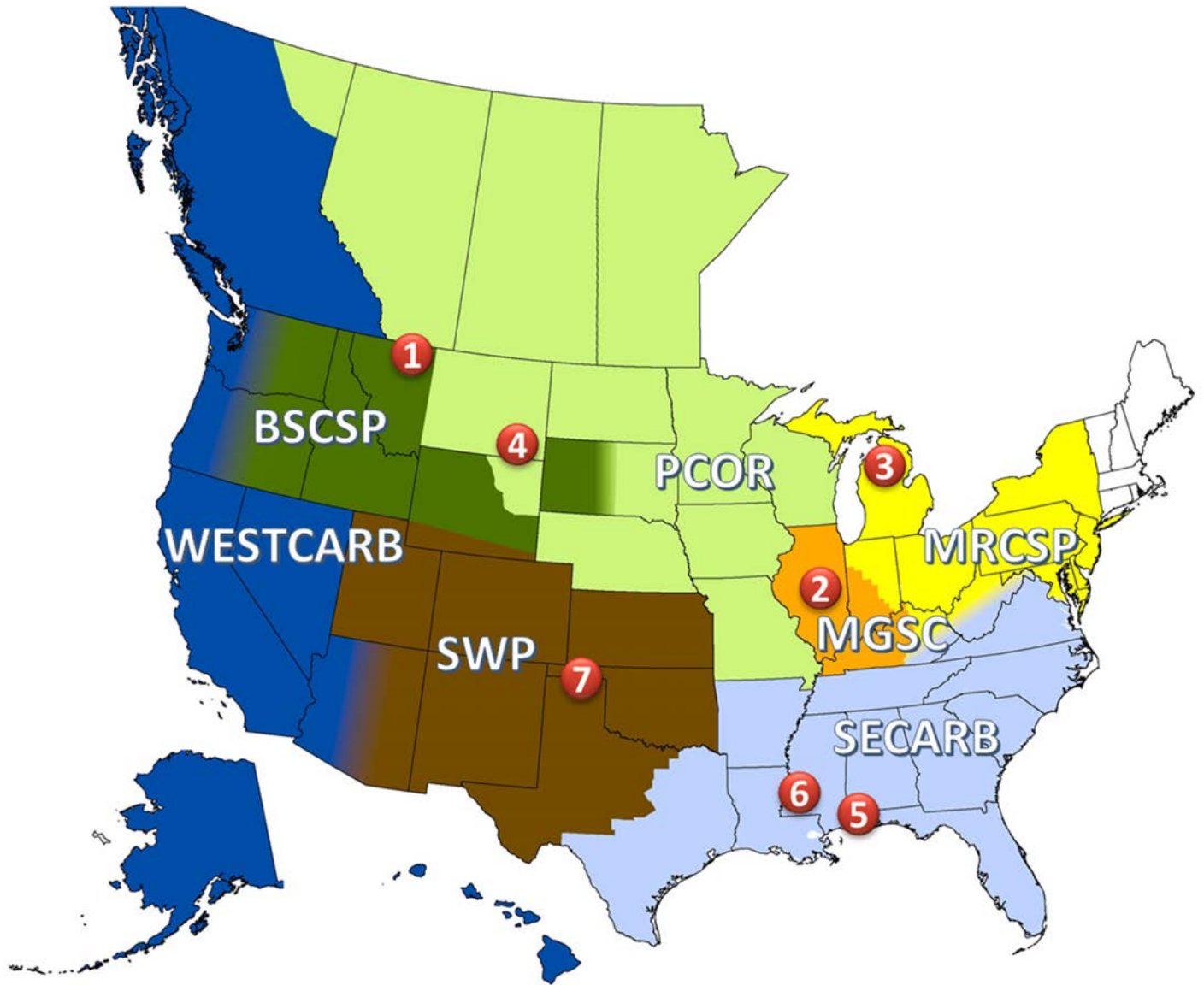

Figure 1: Locations of RCSP Large-Scale Development Phase Projects.
(Numbers correspond to Table 1)

Table 1: RCSP Large-Scale Development Phase Projects.

(See Figure 1 for project locations)

RCSP Development Phase Projects				
Number on Map	Project Name	Project Type	Geologic Basin	Metric Tons of CO ₂ Stored
1	Big Sky Carbon Sequestration Partnership–Kevin Dome Project	Saline Storage	Kevin Dome	N/A (no injection date)
2	Midwest Geological Sequestration Consortium–Illinois Basin Decatur Project	Saline Storage	Illinois Basin	999,215 (final stored, and project in post-injection monitoring phase)
3	Midwest Regional Carbon Sequestration Partnership–Michigan Basin Project	Enhanced Oil Recovery	Michigan Basin	596,282 (as of Sept. 30, 2016)
4	The Plains CO ₂ Reduction Partnership–Bell Creek Field Project	Enhanced Oil Recovery	Powder River Basin	2,982,000 (final stored, and project in post-injection monitoring phase)
5	Southeast Regional Carbon Sequestration Partnership–Citronelle Project	Saline Storage	Interior Salt Basin, Gulf Coast Region	114,104 (final stored, and project in post-injection monitoring phase)
6	Southeast Regional Carbon Sequestration Partnership–Cranfield Project	Saline Storage	Interior Salt Basin, Gulf Coast Region	4,743,898 (final stored, and project in post-injection monitoring phase)
7	Southwest Carbon Sequestration Partnership–Farnsworth Unit Project	Enhanced Oil Recovery	Anadarko Basin	490,720 (as of Sept. 30, 2016)

2.0 MONITORING, VERIFICATION, AND ACCOUNTING PLAN DEVELOPMENT

This chapter discusses development of risk-based MVA plans for a geologic storage project. Content and strategies for developing risk-based plans are discussed, and examples of MVA plans are provided.

Risk analysis, reservoir management, and monitoring design are all closely linked and form the basis of a successful geologic storage project. A project's MVA plan should have a broad scope, including CO₂ containment, monitoring techniques for internal quality control, and verification and accounting for regulators (Det Norske Veritas, 2010a).

Typical MVA plans include components for monitoring the CO₂ plume and water/brine behavior, detecting potential release pathways, quantifying releases, and meeting regulatory requirements (European Commission, 2011). The monitoring plan also defines monitoring objectives, risk-based performance metrics, and resources allocated for monitoring activities. In addition, a comprehensive plan should include reviews of monitoring tools' effectiveness, procedures for documenting monitoring activities, processes used to evaluate monitoring performance, and stakeholder communication.

MVA plans may change in scope as a project progresses from the pre-injection phase to the post-injection phase. In the pre-injection phase, project risks are identified, monitoring plans are developed to mitigate these risks, and baseline monitoring data is obtained. During the injection phase, monitoring activities are focused on containment

and storage performance. Monitoring techniques may need to be adapted and evaluated to ensure that they continue to be effective for meeting established MVA goals. In the post-injection phase, monitoring activities are focused on long-term storage integrity and managing containment risk.

2.1 RISK-BASED MONITORING STRATEGIES

Each CO₂ injection project has its own set of priorities, risks, monitoring targets, and requirements for project success. A site-specific, risk-based monitoring plan is designed to mitigate negative impacts and reduce uncertainties by iterative application of monitoring and risk analysis (Figure 2). Identifying potential risks during site characterization, baseline, or subsequent monitoring operations allows targeted actions to mitigate risk impacts or to prevent their occurrence. In turn, monitoring plans are related to risk prevention and mitigation measures. For further details on risk assessment for geologic storage, the reader is referred to the International Energy Agency Greenhouse Gas Research and Development Programme (IEAGHG) report on risk assessment guidelines and terminology (IEAGHG, 2009), the International Performance Assessment Center for Geologic Storage of Carbon Dioxide (IPAC-CO₂) standard on geologic CO₂ storage (CSA Z741, 2012), and the DOE/NETL BPM for Risk Management and Simulation for Geologic Storage Projects (NETL, 2016a), to be published this year.

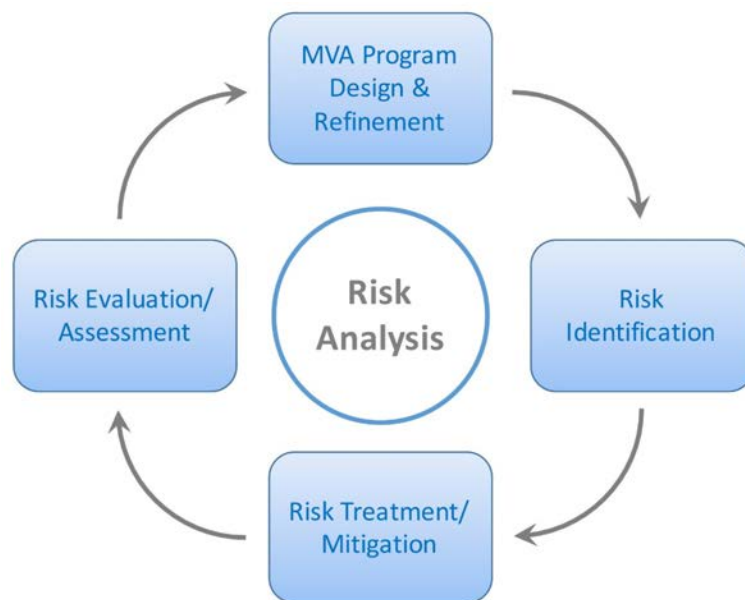

Figure 2: Iterative MVA and Risk Analysis; Adapted from Det Norske Veritas (2010a), IEAGHG (2009)

2.1.1 WORKFLOW FOR DEVELOPING SITE-SPECIFIC MVA PLANS

The first stage in the preparation of a site-specific MVA plan (Figure 3) is identification of risks based on available data, high-level project goals, performance targets, and regulations (DNV 2010b). Not all elements of this generic workflow may be incorporated into each site's MVA design methodology. Rather, risk analysis and reservoir management would be tailored to site-specific needs to ensure successful project operation. Risk-source identification uses risk scenarios, which are aggregated from features, elements, or processes (FEPs) relevant to the specific site. FEPs of concern may be the presence of abandoned wells penetrating the injection zone and elevated injection pressures. Scenarios of higher concern form the basis for risk-mitigation actions and define monitoring targets.

Measurement techniques and safeguards for monitoring targets are identified in the next stage. Each active safeguard has a sensor for parameter measurement, decision logic to respond to the measurement output, and a control response to mitigate risk and inform the project operator. In the next stage, the selected monitoring techniques are screened and

evaluated to identify the most cost-effective technique for a particular monitoring target. This can be accomplished by qualitative subject matter expert judgment (which may include upwards of 15 to 30 project professionals) or relative cost-versus-benefit studies, such as the Boston Square approach (Mathieson, 2011).

The fourth stage in the workflow is the preparation of base case and contingency monitoring and verification plans. The base case monitoring plan covers activities that follow a planned schedule, whereas the contingency plan monitoring activities only occur in the event of release detection. The verification plan ensures that actual storage performance is consistent with the predicted performance. Together, the monitoring and verification plans document the allocation of responsibilities for individual monitoring tasks and the effectiveness of monitoring techniques.

The final stage is accounting and reporting. The MVA plan should describe the procedures for accounting and reporting, which will likely follow a mass balanced approach based on the amount of CO₂ received for injection compared to the amount stored. The frequency, detail, and recordkeeping requirements should also be specified in the plan.

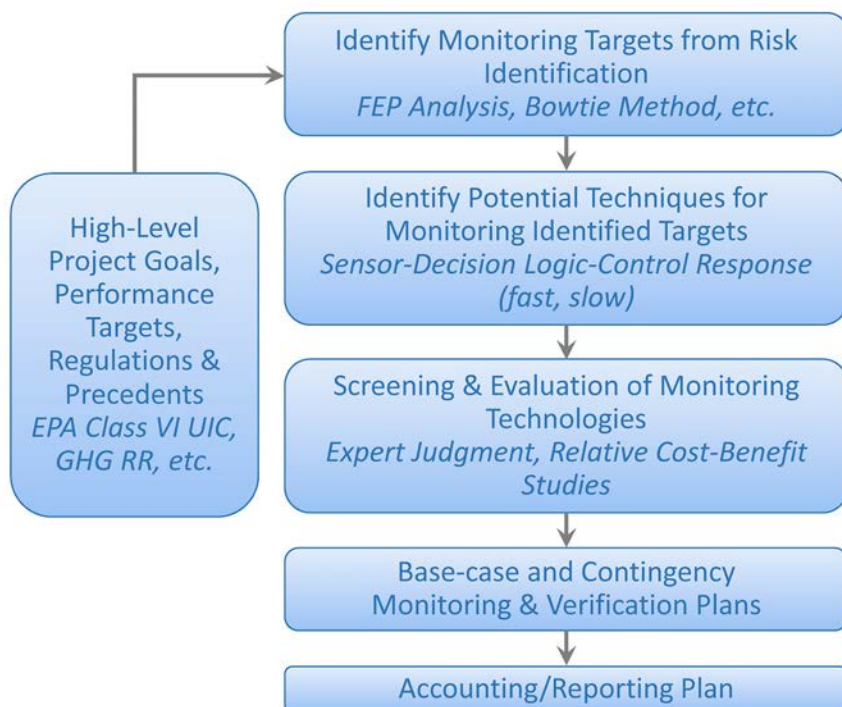

Figure 3: Workflow for the Preparation of a Risk-Based MVA Plan; Adapted from Det Norske Veritas (2010b)

2.1.2 EXAMPLES OF RISK-BASED MVA PLAN WORKFLOWS

The “Bowtie Method” (Shell, 2010; DNV, 2010a) was used to identify and assess containment (release) and storage performance (conformance) risks in the Shell QUEST saline storage project. Monitoring targets and four groups of monitoring tasks were identified, and monitoring technologies were ranked using expert opinions and lifecycle cost-benefit estimates (Figure 4), leading to base case and contingency monitoring plans.

CCS monitoring plans can also be designed by identifying risk scenarios of concern and ranking them in a risk matrix (likelihood-severity scale) by semi-quantitative risk assessment methods. In this context, the CarbonWorkflow™ approach involves ranking of risks to project success using a common scale. Risks that are ranked above a certain tolerance threshold, and which might be mitigated with additional characterization or monitoring, are designated as monitoring targets and guide the design of the monitoring plan (Hnottavange-Telleen, 2013).

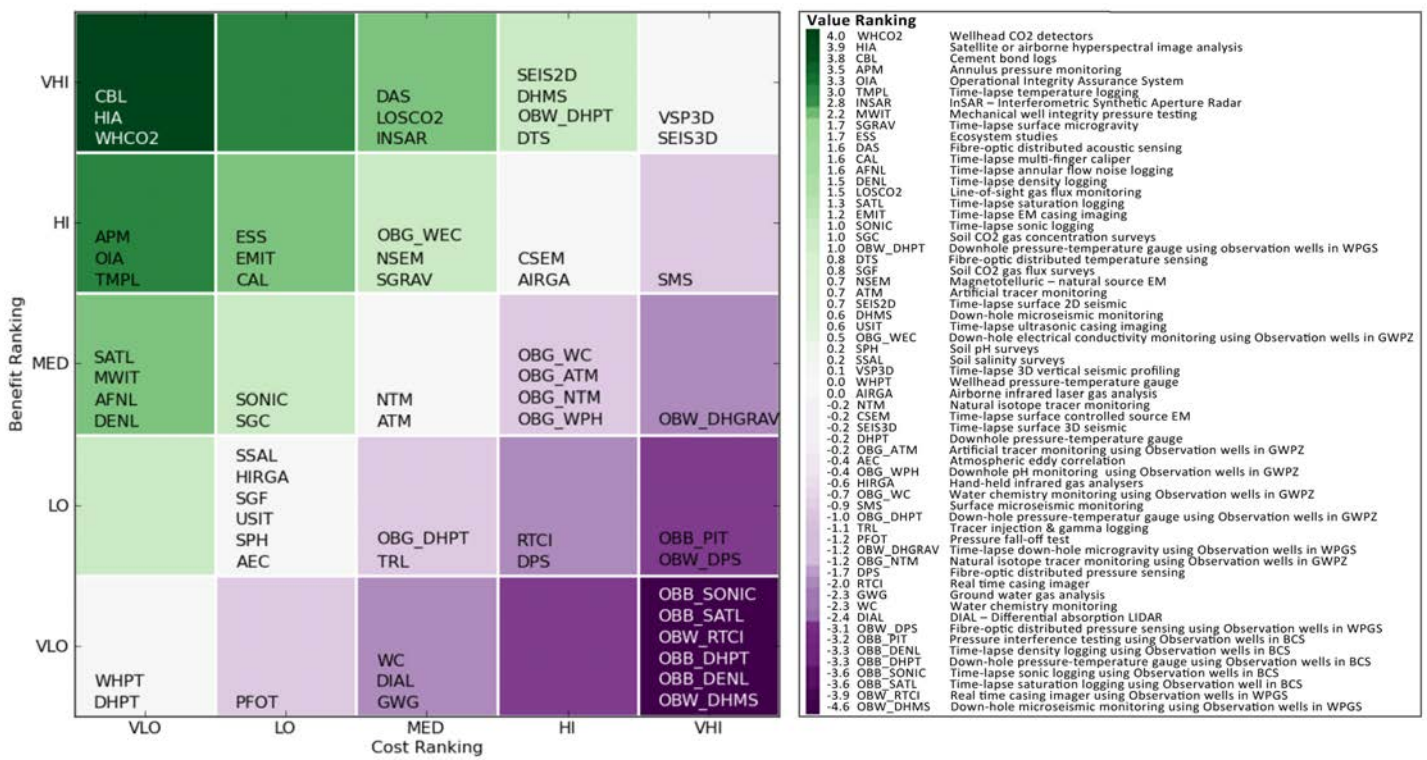

Figure 4: Shell QUEST CCUS Project Cost-Benefit Ranking of Monitoring Technologies (2010)

The Midwest Geological Sequestration Consortium (MGSC) Illinois Basin – Decatur Project used the CarbonWorkflow™ approach (Hnottavange-Telleen, 2014) involving 29 surface and subsurface project experts. This application is more encompassing than developing a CCS monitoring plan but serves as an excellent example of the approach. The 29 experts, working in groups, defined the severity and likelihood (S and L values) for 119 FEPs with strong spatial characteristics, such as those related to the injection wellbore and simulated plume footprint, and “nonspatial” FEPs related to finance, regulations, legal, and stakeholder issues. Within these working groups, experts shared information, examined assumptions, refined and extended the FEP list, calibrated responses, and provided initial S and

L values by consensus. Individual rankings were collected in a follow-up process via spreadsheets. Figure 5 shows the plotted (S,L) risk coordinates for each of 119 FEPs evaluated by at least four individuals. The data point that falls in the red (Severity = -3, Likelihood = 4) grid cell is the top ranked FEP listed in Table 2. Note that some risks that relate to a financial issue (exogenous economics, supply prices) cannot be reduced via monitoring and would not be addressed in the MVA plan. Progressively lower-ranked FEPs are plotted in the yellow and green cells, and the lowest-risk FEPs fall into the blue (negligible risk) cell. Project risk management work focuses on scenarios derived mainly from the approximately 40 FEPs whose S,L coordinates plot in and near the yellow grid cells.

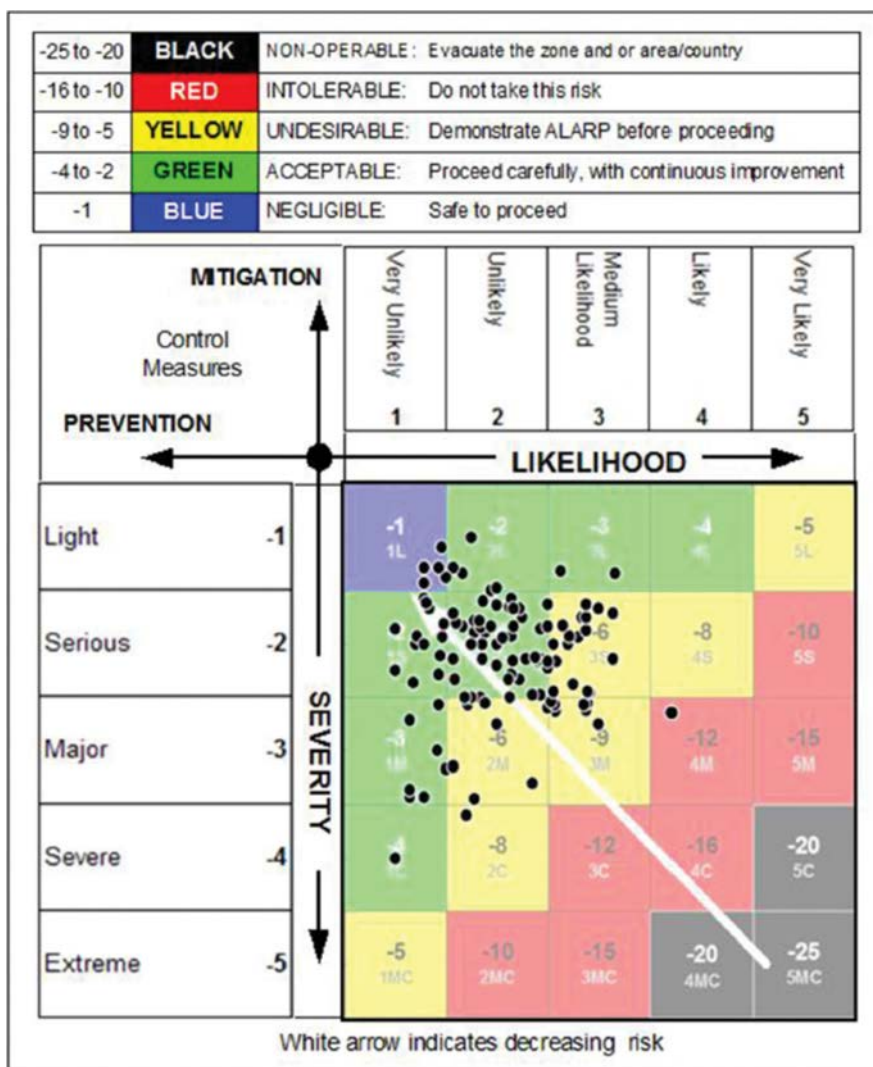

Figure 5: Plotted Severity and Likelihood Risk Coordinates for Each of 119 FEPs

(The product Severity times Likelihood is defined as Risk; the highest-risk FEP plots in the red square where S=-3 and L=4). (Courtesy MGSC)

Table 2: Risk-Related FEPs

(Top 64 of 119 evaluated FEPs are shown, ranked by Risk = Average Severity*Average Likelihood) Courtesy MGSC

Rank	FEP	Risk	Rank	FEP	Risk
1	Exogenous economics, supply prices	10.3	33	Displacement of formation fluid (capillarity)	5.3
2	CO ₂ solubility and aqueous speciation	8.9	34	Accidents and unplanned events: External	5.3
3	Toxic geologic components (metals)	8.1	35	Legal/regulatory: construction, discharge, and other operations permits	5.2
4	Fractures and faults	7.8	36	Drilling and completion activities: Project	5.2
5	Compressor procurement	7.8	37	Thermal effects on the injection point in the formation	5.2
6	Legal/regulatory: Underground Injection Control permit	7.7	38	CO ₂ release to the atmosphere	5.1
7	Schedule and planning	7.4	39	Actions and reactions – SIGs and NGOs, national/international	5
8	Compression facility construction	7.2	40	Over-pressuring	5
9	Undetected features	7.2	41	Shallow gas, drift gas	5
10	Human activities in the surface environment: onsite	7	42	Stress and mechanical properties	5
11	Mechanical processes and conditions	7	43	Sealing and closure of boreholes	4.9
12	Mineral precipitation	7	44	System performance	4.9
13	Seal failure (in wells)	6.9	45	Unplanned CO ₂ release to the atmosphere	4.9
14	Legal/regulatory: Property rights and trespass	6.8	46	Meteorology, weather	4.9
15	Seismicity (Induced earthquakes)	6.5	47	Land and water use	4.8
16	Undefined specification	6.3	48	Soils and sediments	4.8
17	Contamination of groundwater by CO ₂	6.2	49	Mineral dissolution – caprock	4.7
18	Actions and reactions – local community	6	50	Support from MGSC partners	4.7
19	Near-surface aquifers and surface water bodies	6	51	Seal: Geologic, additional	4.6
20	Reservoir pore architecture	5.9	52	Support from government – political basis	4.6
21	Reservoir geometry	5.8	53	Support from government – technical basis	4.6
22	Accidents and unplanned events: Project	5.7	54	Model and data issues	4.5
23	Mineral dissolution – reservoir	5.7	55	Monitoring or verification wells	4.4
24	Community characteristics	5.7	56	Data acquisition activities at well	4.4
25	Heterogeneity in reservoir	5.6	57	Blowouts	4.3
26	Seal: Geologic, primary (caprock)	5.6	58	Lithification and diagenesis	4.3
27	Heterogeneity of overlying aquifers	5.5	59	Construction and operations activities	4.3
28	Mineral dissolution – borehole	5.5	60	Formation pressure	4.3
29	Pressure effects on caprock	5.5	61	CO ₂ injectate quantity and rate	4.3
30	Formation damage	5.4	62	Legal and regulatory framework	4.3
31	Well lining and completion	5.4	63	Post-project monitoring of storage	4.2
32	Lithology	5.3	64	Actions and reactions – SIGs and NGOs, local regional	4.1

Case Study 2.1 describes the Plains CO₂ Reduction (PCOR) Partnership's MVA Plan for the CCS project near Ft. Nelson.

▶ See page 23

2.2 RCSP CASE STUDY

CASE STUDY 2.1 — PCOR

PLAINS CO₂ REDUCTION (PCOR) PARTNERSHIP

PCOR Designing an MVA Program to Reduce Risk and Meet Regulatory Requirements

The Canadian Standards Association (CSA) released a standard for geologic storage of CO₂, entitled “Z741-12 Geological Storage of Carbon Dioxide,” (hereafter referred to as the CSA standard; CSA, 2012) in October 2012. The CSA standard provides guidance for what it considers to be the six key elements of a CCS project: (1) management systems; (2) site screening, selection, and characterization; (3) risk management; (4) well infrastructure development; (5) monitoring and verification; and (6) cessation of injection.

The Plains CO₂ Reduction (PCOR) Partnership developed an MVA plan for a potential future CCS project near Fort Nelson, British Columbia, Canada. The key elements of that plan were examined with respect to how well they address the CSA standard. The Fort Nelson project was compared to the three most applicable key elements of the CSA standard in the effort to develop an MVA plan: (1) site screening, selection, and characterization; (2) risk management; and (3) monitoring and verification.

The CSA standard presents criteria for site screening, site selection, site characterization and assessment, and modeling for characterization (13 criteria address aspects of site screening, 29 address surface and subsurface criteria for site selection, and more than 60 are aimed at site characterization and assessment). Modeling for characterization is covered by approximately 100 criteria. A comparison of the CSA standard to the Fort Nelson project efforts shows that the project clearly addressed all of the site selection, characterization, and modeling criteria. In fact, the Fort Nelson project exceeded a majority of those CSA standard criteria. The CSA standard includes approximately 120 specifications for risk management for which the Fort Nelson project met, and in many cases exceeded, CSA standard criteria.

The CSA standard presents many monitoring and verification program-required specifications. These specifications range from those that are relatively straightforward, such as planned injection rates and total mass of CO₂ to be stored, to complex subjects that require multidisciplinary study. The CSA standard states that the MVA program must provide information on 19 different categories. Several of these are broken down into subcategories, with each requiring its own specific information. This results in approximately 80 criteria that must be addressed by the MVA plan. A comparison of the CSA standard for monitoring and verification to the MVA approach being considered for a hypothetical Fort Nelson project indicates that all of the required specifications and a majority of the recommended specifications would be adequately addressed, should the project ever be implemented.

The efforts at Fort Nelson demonstrated the value of going through multiple iterations of the adaptive management approach. Modifications to the CCS project design were made to reduce risks identified and quantified over the course of two rounds of site characterization, modeling, and risk assessment. Through those iterations, the project planners were able to develop an MVA plan that would satisfy a vast majority of the CSA guidelines.

3.0 CO₂ MONITORING TECHNIQUES

A wide variety of tools and techniques are available for monitoring CO₂ stored in deep subsurface geologic storage sites, as well as conducting surveillance to assure that unlikely but potential release from storage is not occurring. Tools have been designed for monitoring in the atmosphere, in the near-surface region, and in the subsurface (Figure 6). This chapter presents basic information on existing monitoring tools, including a discussion of how each type of tool is used, what it measures, and its advantages and limitations. Examples are provided to illustrate lessons learned from field-testing and utilization. Current and ongoing research activities are also provided, along with goals for improving existing tools and advancing the state-of-the-art in CO₂ monitoring. Additional details can be found in the Carbon Storage Program Review proceedings at: <http://www.netl.doe.gov/events/conference-proceedings/2015/2015-carbon-storage-project-review-meeting>.

Some CO₂ monitoring tools and techniques are tested and field-ready, while others are still being developed. Technologies such as reflection seismic imaging and well logging, for example, were established and tested by the petroleum industry over many decades, in situations with similarities to CO₂ storage projects. As a result, these methods have been readily adapted to CO₂ storage applications, and they have, in fact, been successfully demonstrated at commercial-scale CO₂ storage projects. Other techniques, such as the use of in-ground and surface sensors and unmanned aerial vehicles (UAV) to directly detect and quantify seepage of CO₂ and methane (CH₄) into the soil and atmosphere, are still at early stages of development and have been tested only in a laboratory or in pilot-scale field studies.

As large volumes of monitoring data are acquired using diverse monitoring approaches, a major challenge has been finding ways to streamline and optimize data processing and data integration. A summary of new techniques and new software developed specifically for optimizing MVA data integration and analysis is provided at the end of this chapter.

3.1 ATMOSPHERIC MONITORING

Atmospheric monitoring could play an important role in assuring the general public that the injected CO₂ remains in the subsurface. A reliable, aboveground monitoring system capable of detecting elevated levels of atmospheric CO₂ that may have been released from wellbores, faults, or other conduits may be part of the MVA program in order to provide an additional line of evidence that migration to the atmosphere is not occurring.

3.1.1 REGULATORY REQUIREMENTS

EPA Class VI well regulations are designed to protect underground sources of drinking water (USDWs) from potential CO₂ releases from a geologic storage project. These regulations outline requirements for monitoring to ensure groundwater protection, including post-injection site care, but do not prescribe specific monitoring technologies. Monitoring tools that could be associated with groundwater protection are described in the near-surface tools and approaches section (Section 3.2.3). Under subpart RR of the Greenhouse Gas Reporting Program, facilities carrying out geologic storage operations must report basic information on the amount of CO₂ received for injection; develop and implement an EPA-approved monitoring, reporting, and verification (MRV) plan; and report the amount of CO₂ stored and annual monitoring activities (EPA, 2016b). The MRV plan must specify a strategy for detecting and quantifying surface release of CO₂ and an approach for establishing baselines for monitoring CO₂ surface releases. The MRV plan identifies the maximum monitoring area (MMA) and the active monitoring area (AMA). The MMA is defined as the “area that must be monitored under this regulation and is defined as equal to or greater than the area expected to contain the free phase CO₂ plume until the CO₂ plume has stabilized plus an all-around buffer zone of at least one-half mile.” This represents the expected maximum area to be monitored for CO₂ throughout the life of the project. The AMA is defined as an overlay between “(1) The area projected to contain the free phase CO₂ plume at the end of year t, plus and all-around buffer zone of one-half mile or greater if known release pathways extend laterally more than one-half mile; and (2) The area projected to contain the free phase CO₂ plume at the end of year t+5.”

The MRV plan must be developed by the project supervisor and approved by the EPA Administrator. Once the required reports are submitted to EPA, they will be evaluated to determine if the CO₂ plume is being properly contained and safely monitored. The boundaries of the AMA must be periodically re-evaluated and approved by the EPA Administrator. As the AMA increases, the MVA plan will need to be reviewed to better assure proper containment. For more information on EPA Class VI Rules and Guidelines please consult the EPA website (EPA, 2016a and EPA, 2016b).

3.1.2 ATMOSPHERIC BASELINES

Atmospheric CO₂ levels are impacted by numerous environmental factors, such as seasonal variance, topography, and ecosystem performance (plants, animals, and organisms), as well as other activities emitting to the atmosphere, such as stationary or mobile CO₂ sources. Therefore, atmospheric monitoring protocols likely require detailed evaluation to spacially and statistically characterize the sources of variability, as well as any potential signal from migration of stored CO₂. This characterization, prior to CO₂ injection, is sometimes described as “baseline”; however, it is important to use this data within a forward model to design a system that can isolate a response indicating potential release from other sources of variability. It has been frequently

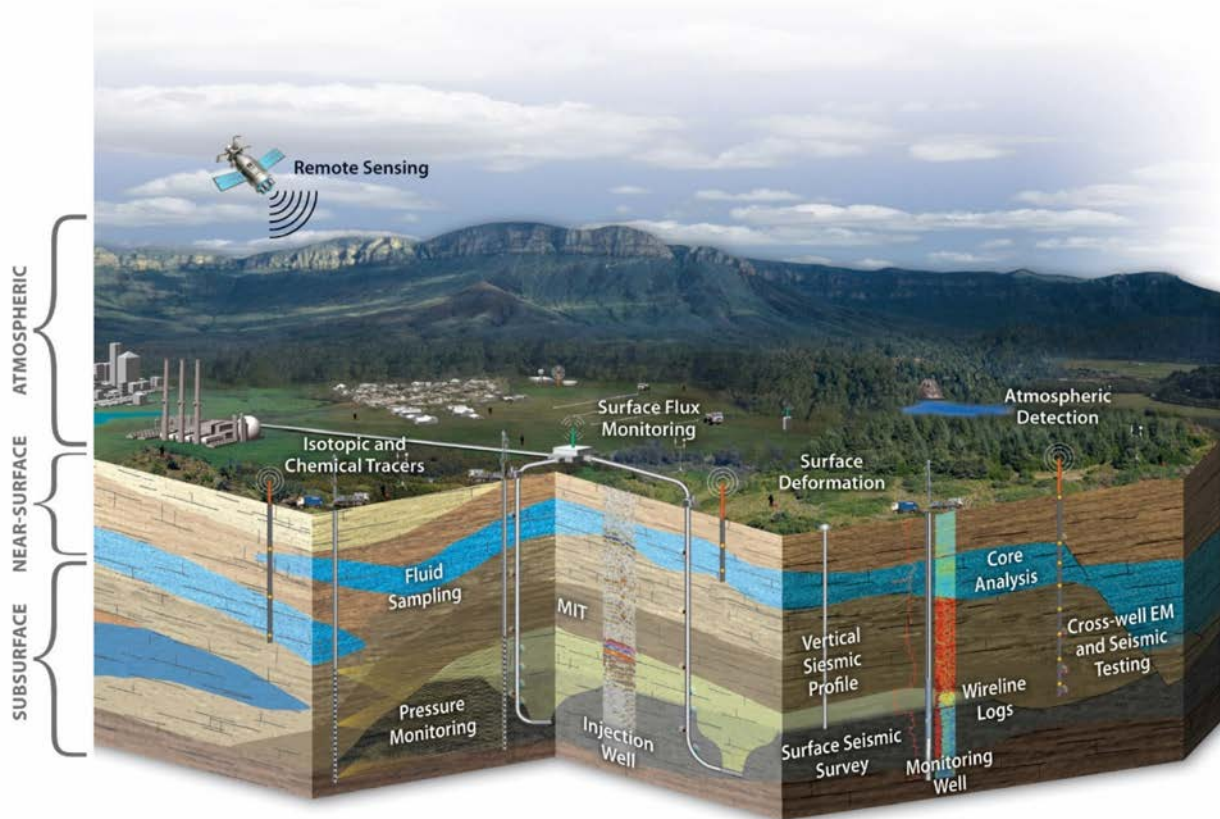

Background Image Courtesy of Schlumberger Carbon Services

Figure 6: Conceptual Diagram of Atmospheric, Near-surface, and Subsurface Monitoring of Carbon Storage Operations.

recommended that baseline periods extend for more than a year prior to injection, but the duration can be technique- and situation-dependent. Typical variation in GHGs are shown in Figure 7, which depicts hourly averaged concentrations of CO₂, CH₄, and water vapor measured at the Arcturus GHG monitoring station in the Bowen Basin, Australia, over a 30-month period (Wilson et al., 2012). Carbon dioxide concentration ranges from 373 to 531 parts per million (ppm) and is influenced by crop growing, pasture, cattle grazing, and natural gas and coal mining activities.

3.1.3 ATMOSPHERIC TOOLS AND APPROACHES

In oil and gas field operations, atmospheric monitoring has been initially employed to safeguard employees and to ensure no leaks were occurring in aboveground equipment. For geologic storage applications, a number of field-deployable monitoring techniques have been developed in recent years for detecting and quantifying atmospheric CO₂ emissions above injection sites, wellheads, and abandoned well sites. These tools are intended to provide assurance or demonstrate that CO₂ from underground storage is not being released to the atmosphere, and if it is to allow for quantification and mitigation. The three most common atmospheric monitoring techniques considered are: (1) optical CO₂ sensors, (2) atmospheric tracers, and (3) eddy covariance (EC) flux measurement.

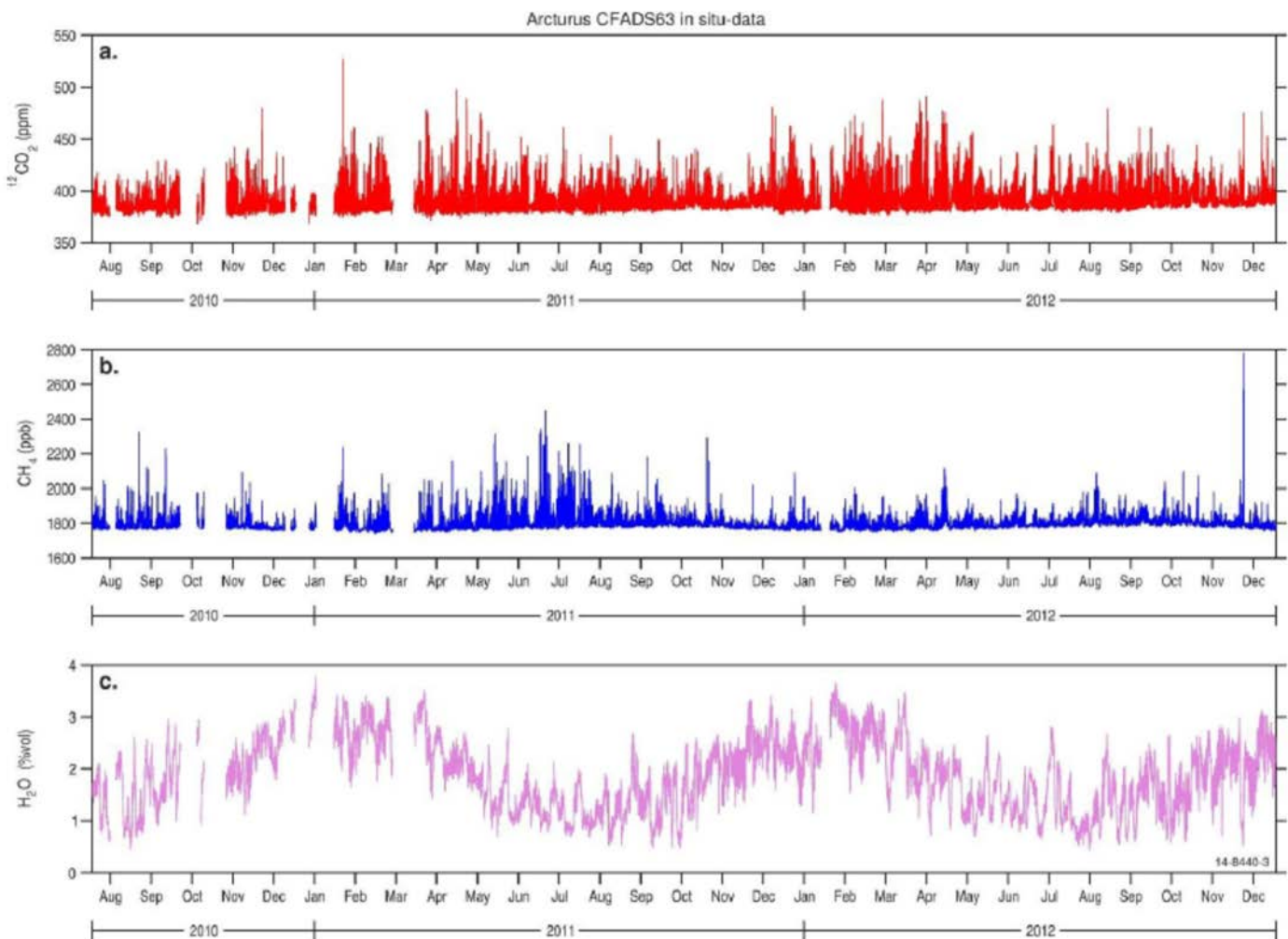

Figure 7: Hourly Averaged Concentration Measurements of CO₂, CH₄, and H₂O from July 2010 to December 2012, Taken at Arcturus GHG Monitoring Station Near Emerald, Queensland, Australia.

(Source: Wilson et al., 2014)

Table 3: Summary of Atmospheric Monitoring Techniques

Atmospheric Monitoring Techniques	
Monitoring Technique	Description, Benefits, and Challenges
Optical CO₂ Sensors	<p>Description: Sensors for intermittent or continuous measurement of CO₂ in air.</p> <p>Benefits: Sensors can be relatively inexpensive and portable.</p> <p>Challenges: Difficult to distinguish release from natural variations in ambient-CO₂ emissions.</p>
Atmospheric Tracers	<p>Description: Natural and injected chemical compounds that are monitored in air to help detect CO₂ released to the atmosphere.</p> <p>Benefits: Used as a proxy for CO₂, when direct observation of a CO₂ release is not adequate. Also used to track potential CO₂ plumes.</p> <p>Challenges: In some cases, analytical equipment is not available onsite, and samples need to be analyzed offsite. Background/baseline levels must be established. Tracers may not behave the same as CO₂ along the migration pathway.</p>
Eddy Covariance	<p>Description: Flux measurement technique used to measure atmospheric CO₂ concentrations at a specified height above the ground surface.</p> <p>Benefits: Can provide continuous data, averaged over both time and space, over a large area (hundreds of meters to several kilometers).</p> <p>Challenges: Specialized equipment and robust data processing are required. Natural spatial and temporal variability in CO₂ flux may mask release signal.</p>

Each technique (summarized in Table 3) has its benefits and its challenges. Optical sensors, for example, can provide continuous or intermittent measurement of CO₂ in a localized area, but they are not well-suited to monitoring over large areas. In addition, they are not able to differentiate between CO₂ released from storage and natural variations in ambient CO₂. Atmospheric tracers, while useful as a proxy for CO₂, may require the use of analytical equipment that is not typically available at CO₂ storage sites. The EC technique has the potential to be a powerful tool because it can provide a time-averaged and spatially averaged dataset over a large area. However, EC data processing is highly complex.

A description of each of these atmospheric monitoring techniques is provided below, along with a summary of lessons learned from the field and an introduction to current and ongoing research.

3.1.3.1 OPTICAL SENSORS

Optical CO₂ sensors may be deployed aboveground to monitor release of CO₂ to the atmosphere. For environmental, safety and health (ES&H) applications, automated sensors are in some cases deployed to trigger alarms when CO₂ levels exceed a pre-determined safety threshold. Common optical sensors are based on infrared (IR) spectroscopy, cavity ring-down spectroscopy (CRDS), or light detection and ranging (LIDAR). Commercially available CO₂ detectors for ES&H monitoring use non-dispersive infrared (NDIR) spectroscopy. All of these sensors measure absorption of IR radiation along the path of a laser beam or other light source. Carbon dioxide concentration is computed based on the degree of absorption of particular wavelengths. Each sensor type differs in its resolution, its response to CO₂, and the level of sample conditioning and data processing required to produce meaningful results. Common problems with optical CO₂ sensors are: (1) cross-sensitivity to other gas species,

such as water vapor and CH₄, and (2) temporal and thermal calibration drift. It may be possible to minimize these problems by collecting spatially separated, geo-referenced CO₂ gas concentration measurements at regular time intervals, using a ground-based or airborne vehicle. A limitation associated with these types of mobile surveys is that they require long-term land access to field sites over large areas (e.g., hundreds of square kilometers).

Optical sensors have been used during international carbon storage projects in Africa and Australia not funded by DOE. Optical sensors based on a mobile, open-path IR laser system were deployed at the In Salah CO₂ storage project in Algeria in order to monitor near-ground, atmospheric CO₂ near injection wells (Jones et al., 2010). Carbon dioxide concentrations were measured near two injection wells and in the region between an injection well and a plugged well. No anomalous CO₂ concentrations were detected in these areas. However, the open-path IR sensors were found to be unreliable in dusty, windy conditions. Airborne dust within the laser beam and dust settling on external optical surfaces made it difficult to separate the effects of dust from variations in atmospheric CO₂ content. In an effort to provide insight concerning the size of CO₂ releases that could be detected and the proximity required for detection, Wilson et al., (2014) collected samples of GHGs from July 2010 to June 2014 in the Bowen Basin, Australia utilizing a CRDS. Figure 7 shows variation of CO₂, CH₄, and water vapor with respect to time. Using this data, a statistical model was created to predict the major features of background CO₂. The model was used to determine that the minimum-sized CO₂ release that could be detected is 22 tonnes per day (tpd) for a 100 m x 100 m area source and 14 tpd for a point source when the release is approximately 1 km from a single monitoring station. These are very large sources located short distances from the station and have a high alarm rate of 56 percent. The sensitivity of detection could be greatly improved through additional stations, more information prior to a potential release (e.g., possible CO₂ plume migration), or better estimates of the background CO₂. This study suggests that atmospheric monitoring for CO₂ at a geologic storage site using a single station is more suitable for monitoring and quantification of an identified release (i.e., the instrument can be located close to the release and in an optimal location) rather than kilometer-scale CO₂ release detection over vegetated regions.

Lessons Learned from the Field: Optical Sensors

Some of the most valuable lessons learned have been from controlled release experiments, where a site is engineered to simulate a release and then many instruments can be deployed to test the sensitivity and best practices for detection and quantification. Extensive controlled release experiments have been conducted at a facility designed and operated by Montana State University (MSU), known as the Zero Emission Research and Technology Center (ZERT), and at the Australian Ginninderra site. At each site, a horizontal pipeline was installed at shallow depths in an agricultural area, and filling the pipeline with CO₂ allowed many experiments in detection to be performed. These series of tests are referred to throughout this chapter; Spangler et al. (2010) provides additional information concerning the ZERT test site and modeling and experimental results, whereas Feitz et al. (2014) provides additional information concerning the Ginninderra site and tests conducted.

In 2006, 2007, and 2008, researchers from MSU tested an aboveground, laser-based sensor at the ZERT facility in Montana during repeated controlled CO₂ release experiments (Humphries, 2008). The CO₂ Detection by Differential Absorption (CODDA) instrument uses a tunable distributed feedback laser that can identify water vapor and CO₂ absorption features based on their wavelengths. The sensor was set up for continuous measurement over the release pipe. Measurements made parallel to the release pipe registered a marked increase in CO₂ throughout the controlled release period. The results revealed a cyclic pattern in CO₂ levels at the site, with lower CO₂ during daylight hours and higher CO₂ at night, presumably due to diurnal effects of temperature, wind speed, and photosynthesis.

Case Study 3.1 summarizes MGSC's experience with the GreenLITE System at the IBDP large-scale field project.

▶ See page 64

Current and Ongoing Research: Optical Sensors

Oklahoma State University is developing and demonstrating an integrated system that is capable of directly detecting and quantifying seepage of CO₂ and CH₄ into the soil and atmosphere. The approach employs in-ground and surface sensors and UAVs to collect data. Oklahoma State University is using the Senseair K-Series CO₂ sensor and the Edinburgh GasCard CH₄ sensor. The Skywalker X-8 was selected as the UAV platform based on its capacity, durability, and stability. The integrated system is ready to be installed, tested, and optimized at the Southwest Regional Partnership (SWP) Farnsworth Unit, large-scale field project.

Exelis is developing a Greenhouse Gas Laser Imaging Tomography Experiment (Green Lite) system that can make high-quality, atmospheric, near-surface CO₂ measurements over an open area by using two scanning Laser Absorption Spectrometer (LAS) instruments and coupling them with a series of retro-reflecting mirrors in a grid network. The prototype system was deployed to the ZERT field site for simulated release tests of realistic scenarios expected for carbon storage sites. The ZERT test delivered an extended dataset for quantified validation of the precision and accuracy of the 2-D concentration and flux maps. The system was further refined and deployed to the MGSC Illinois Basin Decatur large-scale field project, demonstrating real-time autonomous operation (publications pending).

Clegg et al. (2015) are enhancing the LIDAR technology by incorporating an additional laser into the in-situ instrument capable of monitoring hydrogen sulfide (H₂S) and CH₄ with isotope sensitivity. They are using frequency-modulated spectroscopy (FMS) as an ultra-sensitive method to optically monitor trace gaseous species in an in-situ, remote LIDAR instrument. This advanced instrument can monitor the stable isotopes of CO₂ that can potentially distinguish anthropogenic CO₂ from natural CO₂ emissions.

Case Study 3.2 details BSCSP's experience with differential absorption LIDAR at the large-scale Kevin Dome project.

▶ See page 65

3.1.3.2 ATMOSPHERIC TRACERS

Natural and introduced tracers in the atmosphere can also be used for monitoring of a possible CO₂ release from geologic storage reservoirs. Natural tracers are chemical compounds that are associated with CO₂ in the subsurface, near-surface, or atmosphere. These include CH₄, radon, noble gases, and isotopes of CO₂. Introduced tracers, such as sulfur hexafluoride (SF₆) and perfluorocarbon tracer (PFT), are chemical compounds that may be injected into a geologic reservoir along with the CO₂ in order to give the injected CO₂ a unique fingerprint that can be recognized in aboveground emissions. Tracer monitoring can take place in the near-surface and subsurface regions and are also discussed in the respective sections of this chapter.

One challenge in using atmospheric tracers is that they may disperse in the air at different rates than CO₂. Certain tracers disperse more quickly than CO₂, which can result in a background buildup of tracer concentrations beyond the extent of the actual CO₂ plume in the air. Such differences in atmospheric dispersion effects between CO₂ and the tracer need to be understood in order to properly interpret atmospheric tracer data.

Some of the available tracers are powerful GHGs themselves, and therefore application in a GHG context may require a value-versus-risk evaluation to be performed.

Lessons Learned from the Field: Atmospheric Tracers

Monitoring of CO₂ using atmospheric tracers was tested at the Cooperative Research Centre for Greenhouse Gas Technologies (CO2CRC) Otway project in Australia. Tracers make both the detection and the attribution step of monitoring much easier (Myers et al., 2013). Measurements of soil gas, groundwater, and atmosphere at Otway were checked for the presence of SF₆, which while present in the environment at low concentrations, is much less variable than CO₂. Tracer use must be managed with strict protocols to limit cross-contamination, and to reserve tracers for different uses so that they do not interfere or overlap. Flask sampling of tracer gases was also used to investigate unusually high nocturnal CO₂ concentrations at the Otway monitoring station. Isotopic analyses of the tracer gases, together with flux measurements and air trajectory data, indicated that ecosystem respiration was the likely source of these anomalously high CO₂ levels. This test showed that atmospheric tracer analyses might be used to correctly identify the source of an elevated CO₂ reading that might otherwise be interpreted as a storage release. Additional discussion of tracer measurements and their utility in release detection and other applications is provided in the near-surface and subsurface monitoring techniques sections.

Pekney et al. (2011) conducted atmospheric PFT sampling during controlled CO₂ release experiments at the ZERT facility to develop an autonomous monitoring, sampling, and control system for tracer measurements. A multi-tube remote sampler (MTRS) system, consisting of carousels of sealed sorbent tubes, was deployed with a mobile-tethered balloon, positioned 1 to 30 meters above ground, to sample the PFT co-injected with CO₂. Additionally, wind-vane sampler

(WVS) systems were placed 2 and 800 meters from the CO₂ release zone to sample the air at various elevations above ground. Mock-unmanned-aerial system monitoring was also carried out by circling the MTRS system over the CO₂ release zone. The MTRS and WVS systems (Figure 8) were controlled wirelessly by a ground-based transmitter-receiver system to sequentially expose the sorbent tubes and record

exact global positioning system (GPS) locations for each sample. The mock-unmanned-aerial system trials yielded good correlation between wind-rose data and measured PFT concentration data. A far-field background-buildup of tracer concentrations was observed at the tower 800 meters from the CO₂ release.

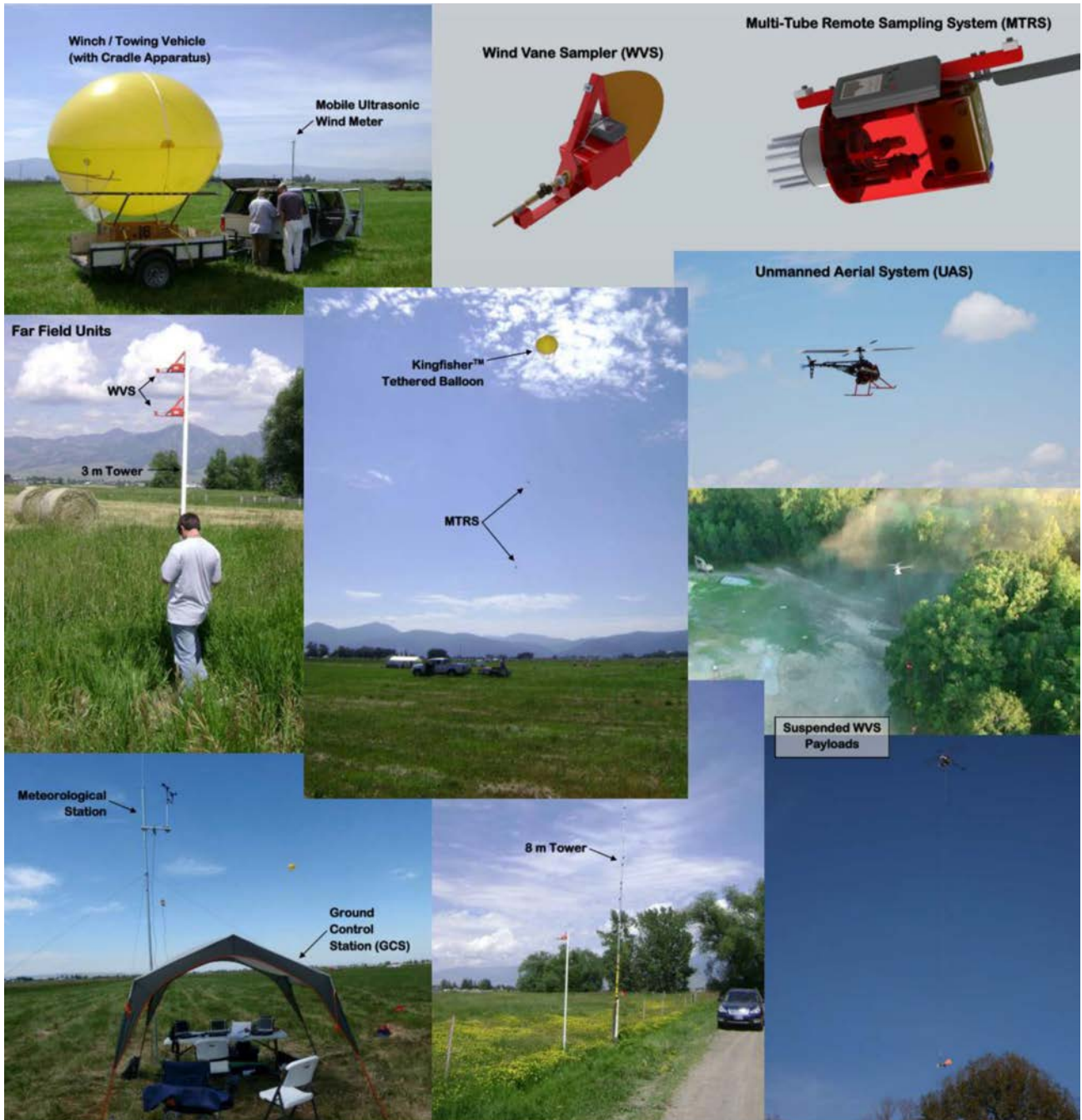

Figure 8: MTRS and WVS Systems for Atmospheric PFT Tracer Monitoring

(Source: Pekney et al., 2011)

Current and Ongoing Research: Atmospheric Tracers

Research and development of the methods for improved use of tracers is currently focused on near-surface and subsurface applications; however, findings may be beneficial for use in atmospheric detection. See Sections 3.2 and 3.3 for more details.

3.1.3.3 EDDY COVARIANCE TECHNIQUE

The EC technique (also known as eddy correlation and eddy flux) has become a popular tool for evaluating net CO₂ exchange from terrestrial ecosystems to the atmosphere, and in recent years, it has been tested for its potential ability to detect CO₂ releases from underground storage reservoirs. Instruments mounted on towers above the land surface are used to measure CO₂ gas concentration, vertical wind speed, relative humidity, and temperature. Carbon dioxide flux is then calculated from these field measurements based on the covariance of CO₂ concentration and instantaneous vertical wind velocity above or below their mean values. Depending on the height of the towers, the resulting CO₂ flux estimates provide a spatial average for an area of up to several square kilometers. Data can be integrated over the time period of interest, which may be several days to a year or more.

The EC technique has some advantages over other atmospheric CO₂ monitoring techniques. The instruments are able to provide continuous measurements over extended time periods, the data can provide a spatial average over a large area, and the environmental impacts of installing the instrument towers are relatively minor. In addition, EC flux data may be supplemented by soil-gas CO₂ flux data and tracer analyses to enhance release detection capabilities. On the other hand, the EC technique requires robust data processing, and natural variability in ecosystem CO₂ fluxes may, in some situations, mask a release signal. As with other CO₂ monitoring techniques, a baseline must be established prior to injection so that the temporal and spatial variability in background CO₂ is known.

Lessons Learned from the Field: Eddy Covariance

EC has the potential to provide automated CO₂ flux measurements over large areas. Research has shown that during a controlled release of CO₂ from a horizontal well, the EC estimated release rate (0.32 tonnes/day) was within seven percent of the measured release rate (0.3 tonnes/day) (Lewicki and Hilley, 2009). Surface CO₂ leakage discharge (tonnes/day) was based on soil-gas CO₂ flux

measurements made repeatedly on a grid (black dots on Figure 9). Lewicki and Hilley (2009) demonstrated the use of EC measurements and ecosystem-CO₂ exchange models to identify the location and magnitude of surface CO₂ releases at the ZERT facility (Figure 9).

An EC flux tower was deployed at the CO₂CRC Otway project in 2007, several months prior to CO₂ injection in 2008. A baseline was established for the site, which showed high background CO₂ concentrations and high natural variability in land-to-air CO₂ fluxes. EC flux data did not show evidence of CO₂ releases during a scheduled CO₂ venting from an observation well. Etheridge et al. (2010) note that dry periods may be the best time to detect CO₂ releases in future tests because this is when natural variations in CO₂ flux are lowest. Data from the flux tower were also used to model ecosystem CO₂ fluxes and atmospheric dispersion at the Otway site.

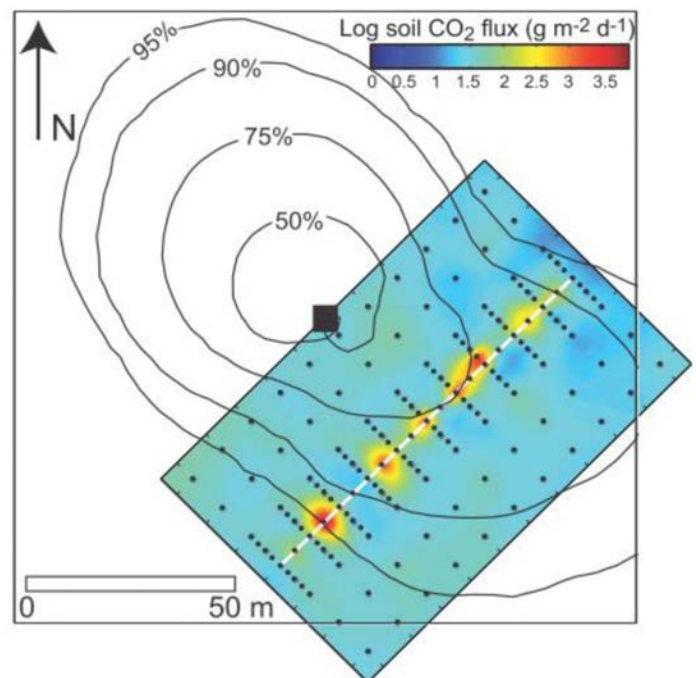

Figure 9: Map of Log Soil CO₂ Flux, Interpolated Based on Measurements Made at the Black Dots on July 25, 2008

(Lewicki and Hilley, 2009)

(The white line and black square show locations of surface trace of CO₂ release well and EC station, respectively. Mean EC flux 50, 75, 90, and 95 percent source area isopleths are shown for the CO₂ release time.)

Current and Ongoing Research: Eddy Covariance

Current research in EC techniques is aimed at developing a method to design an EC network to enhance monitoring of the spatial distribution and magnitude of a surface CO₂ flux release signal (Lewicki and Hilley, 2012). Integrated and distributed estimates of CO₂ surface flux inferred using the network are used to assess tradeoffs between number and location of stations, as well as the determination of the surface flux distribution.

3.2 NEAR-SURFACE MONITORING

Geochemical tools are discussed that identify and quantify possible migration of CO₂ from the subsurface into the vadose zone and shallow groundwater sources. Surface displacement monitoring and ecosystem stress monitoring are also considered. Figure 10 provides a visual look at near-surface monitoring as it relates to other subsurface monitoring techniques.

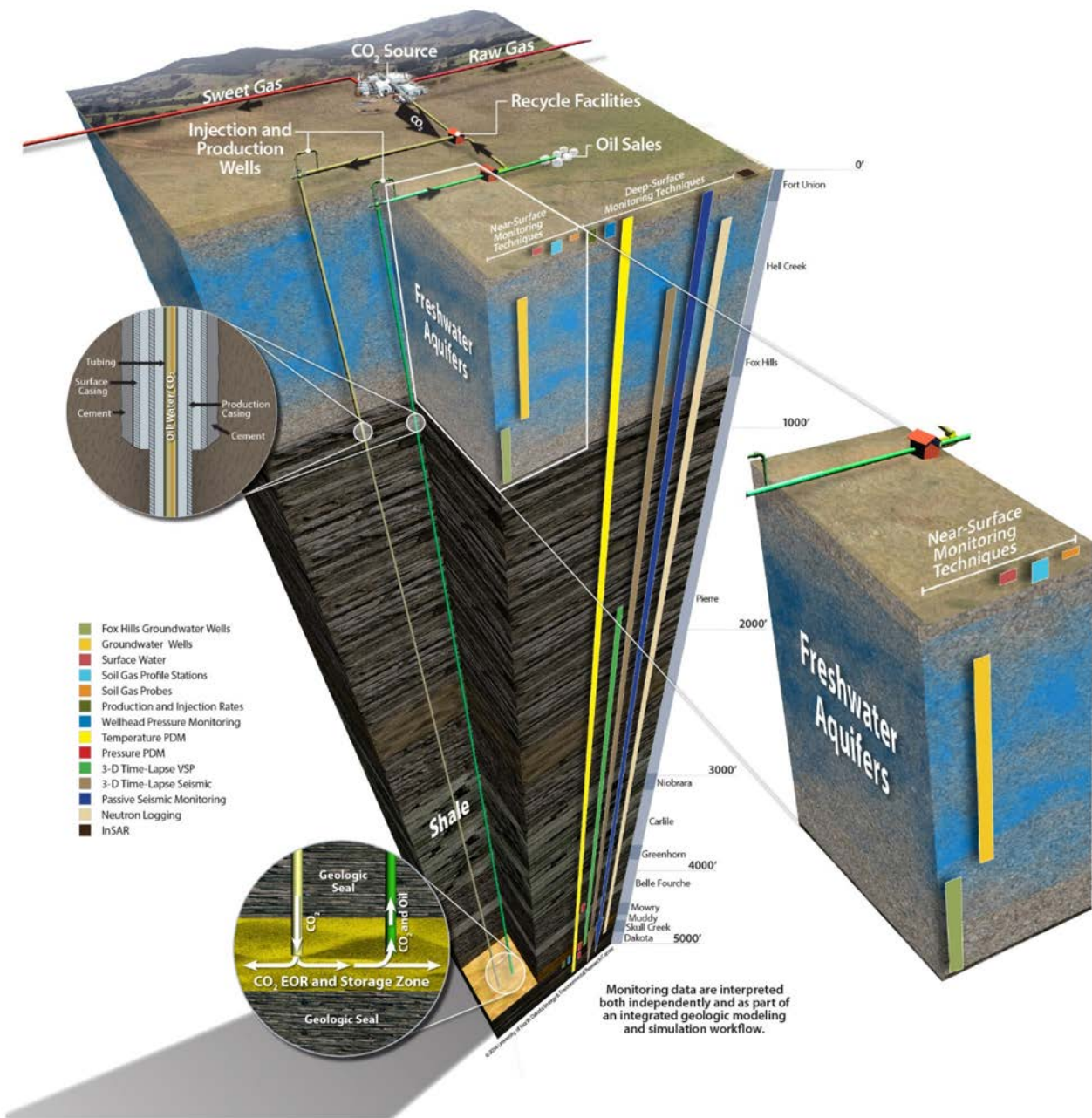

Figure 10: Near-Surface Monitoring in Relation to Other Subsurface Monitoring Techniques (EERC)

3.2.1 REGULATORY REQUIREMENTS

Per EPA UIC Class VI regulations (40 CFR 146.90 – Testing and Monitoring Requirements), the owner or operator of a Class VI well must prepare, maintain, and comply with a testing and monitoring plan to verify that the geologic storage project is operating as permitted and is not endangering USDWs. EPA guidance specifies: “The guidance requires periodic monitoring of the groundwater quality and geochemical changes above the confining zone(s) that may be a result of CO₂ movement through the confining zone.” EPA specifies that monitoring frequency and spatial distribution will be decided using baseline geochemical data for near-surface formations, including all the USDWs in the area of review (AoR). Specific information about the geologic storage project, including injection rate and volume, geology, the presence of artificial penetrations, AoR, and other factors, determines the location and number of USDW monitoring wells to be used. Soil-gas monitoring to detect movement of CO₂ may be required at the discretion of the EPA administrator.

The methodology and instrumentation used to quantify near-surface emissions are not specified in the regulations. Surface displacement monitoring and ecosystem stress monitoring are not required in regulation, although they might lie within the scope of technologies that may be considered.

3.2.2 NEAR-SURFACE BASELINES

Many factors impact the collection of near-surface baseline data for geologic storage projects. For example, having landowner support through landowner site-access agreements, site logistics, weather conditions, and available resources (i.e., budgeting and scheduling to conduct sampling activities) play an important role in deciding the quantity of baseline measurements. EPA emphasizes the need for baseline data to: (1) decide monitoring frequency and spatial distribution of groundwater or soil-gas monitoring in order to describe how the proposed monitoring will yield useful information on compliance with standards, and (2) establish accurate baseline data against which future measurements may be compared.

Although many practitioners have emphasized the temporal and spatial attributes of baseline data collection, the optimization of parameters to be collected and required statistical qualifications to meet EPA's objectives have received less emphasis. Analyzing historical data accumulated over several years collected prior to injection from statistically and geographically representative locations near the injection site may be a useful starting point. The European Union project, Research into Impacts and Safety in CO₂ Storage (RISCS) (Pearce et al., 2014a)

indicates that baseline surveys should be designed to account for a full range of natural variation which may occur over more than one year. In all cases, predictive modeling should be conducted to determine if the data collection will meet the needs in terms of detecting and quantifying migration of injected CO₂.

It may be advisable to emphasize detection of an anomaly that potentially indicates a release as the goal of the deployed monitoring strategy. Detection of an anomaly can then be followed by focused tests to determine if the possible subsurface source can be identified (Dixon and Romanak, 2015). This identification can be followed by additional tests, which may include collecting data needed for mitigation and quantification of the losses. Baseline data considerations for soil-gas, groundwater, ground surface elevation trends, and surface ecosystems are presented briefly below.

Soil-gas methods assess the chemistry of the gas-phase dominant in the vadose zone; groundwater methods extract the aqueous phase from permeable zones in the freshwater saturated system that typically underlies it. These are different systems in terms of both background processes and in predicted response to possible CO₂ migration from depth.

Soil gases are a mixture of atmosphere introduced by barometric pumping into the vadose zone, gasses generated in-situ, and any gasses introduced from depth. In-situ biological processes, primarily root respiration and microbial oxidation of soil organic matter, typically have a strong impact on the soil-gas concentration, consuming oxygen and producing CO₂, and can shift the isotopic composition of gasses (Klusman, 2005). Soil moisture and minerals can also interact with gasses and shift concentration and composition.

Groundwater is a complex system dominated by surface water recharged at local and distant outcrops of permeable strata; atmospheric and soil gasses including CO₂ are introduced during recharge. As groundwater flows toward local or distant discharge points, the chemical composition of dissolved constituents can be altered by interactions with mineral or organic components of the host aquifer rocks and mixing with fluids from deeper or shallower aquifers or marine intrusion. CO₂ migration may produce a local, significant anomaly; however, the leakage signal may become more difficult to detect away from the source point of migration. One concern specific to CO₂ migration is that the dissolution of CO₂ lowers groundwater pH, which can lead to dissolution of chemical constituents of higher concern than the CO₂ itself (Apps et al., 2010; Carroll et al., 2014; C. Yang et al., 2014a).

Surface displacement monitoring allows inference about pressure changes at depth to be made based on surface response. It has the same requirements for baseline as other techniques, in that the variability resulting from groundwater and other resource recharge and with discharge must be assessed, as well as any ambient controls, such as uplift or subsidence (Karegar et al., 2015).

Surface ecosystem stress monitoring is highly dependent on acquisition of a well-defined baseline. Like other monitoring methods, this data must provide a statistical database and training set that can be used to: (1) define any signals of stress created by migration from depth would have on the surface ecosystem, and (2) separate this signal from other ambient stresses such as rainfall and seasonal changes. Understanding of this method has been developed at controlled release sites, as well as natural analog areas where CO₂ is migrating from depth (Pearce et al., 2014b).

3.2.3 NEAR-SURFACE TOOLS AND APPROACHES

This section provides a summary of examples of near-surface monitoring techniques, including geochemical monitoring in the soil and vadose zone, geochemical monitoring of near-surface groundwater, surface displacement monitoring, and ecosystem stress monitoring. The purpose of these monitoring approaches is to detect near-surface manifestations of CO₂ migrating from the storage reservoir. In addition, this section provides examples of surface displacement monitoring. Surface elevation changes may be caused by increases in fluid pressure during CO₂ injection operations and may be detected by surface displacement monitoring techniques. Each near-surface monitoring technique is summarized in Table 4 and discussed in greater detail below.

Geochemical monitoring in the soil and vadose zone involves direct sampling of CO₂ and its reaction products, as well as sampling for any natural or introduced tracers that may have been injected into underground storage along with the CO₂. Geochemical monitoring of near-surface groundwater involves installation of shallow monitoring wells for measuring potential changes in groundwater chemistry related to CO₂ injection. Characterizing large areas using point measurements requires many individual data collection points.

Surface displacement measurements are designed to detect uplift of the land surface that may have been caused by increases in fluid pressure caused by CO₂ injection, and ecosystem stress monitoring is aimed at mapping vegetative stress that may have resulted from elevated CO₂ levels in the root zone. Remote sensing data can provide highly precise surface displacement measurements and indications of vegetative stress over a large area. However, the data are difficult to interpret.

3.2.3.1 GEOCHEMICAL MONITORING IN THE SOIL AND VADOSE ZONE

The soil and vadose zone extends from the land surface down to the water table and geochemical samples can be collected, either at the surface by placing flux chambers on the ground or accessed by installing various types of shallow well systems. Components to be measured include CO₂ and other gases, natural tracers, and introduced tracers, as well as other minor volatile organic compounds (VOCs). Soil-gas survey designs vary from minimal plotting of CO₂ concentration changes to designs that deal with a relatively complete suite of components involved in the soil-gas system, such as moisture and barometric pressure.

A number of designs to detect and attribute anomalies that could be related to release are possible. Forward modeling is essential to compare background composition and compositional variation to release signals to determine the feasibility of the method selected. The simplest is measurement of baseline soil-gas concentrations, followed by post-injection measurements to detect soil-gas increases that could be related to CO₂ released from the storage reservoir. As an alternative, Romanak et al., (2013) developed a process-based method using ratios of coexisting soil gases (CO₂, oxygen [O₂], nitrogen [N₂], and CH₄) to distinguish a release signal from natural vadose zone CO₂ without the use of background monitoring. This method was applied at a site of alleged release from the IEAGHG Weyburn-Midale CO₂ Monitoring and Storage Project reservoir and showed that no release had occurred (Romanak et al., 2013). A program based on tracers can also be used to detect and attribute leakage signal. Natural chemical tracers (including isotopes of carbon, oxygen, hydrogen, nitrogen, and sulfur, as well as noble gases helium, krypton, neon, and argon) in some cases may differentiate between native CO₂ and injected CO₂. Introduced tracer chemicals, such as PFTs, may be injected with the CO₂ and then monitored in the soil gas. The occurrence of some tracer chemicals is so low in natural systems that detection and attribution can be achieved at a parts-per-billion resolution level. Many of these options can be combined to be collected sequentially to optimize detection and attribution.

Table 4: Summary of Near-Surface Monitoring Techniques

Near-Surface Monitoring	
Monitoring Technique	Description, Benefits, and Challenges
Geochemical Monitoring in the Soil and Vadose Zone	<p>Description: Sampling of soil gas for CO₂, natural chemical tracers, and introduced tracers. Measurements are made by extracting gas samples from shallow wells or from/with flux accumulation chambers placed on the soil surface and/or with sensors inserted into the soil.</p> <p>Benefits: Soil-gas measurements detect shifts in gas ratios or elevated CO₂ concentrations above background levels that may provide indications of gas releases from depth. Tracers aid in identification of native vs. injected CO₂. Flux chambers can quickly and accurately measure local CO₂ fluxes from soil to air.</p> <p>Challenges: Potential for interference from surface processes producing false positives as well as missing signal is significant. Significant effort for potential lack of significant results. Relatively late detection of release. Considerable effort is required to avoid cross-contamination of tracer samples. Natural analogs suggest that migration may be focused in small areas and flux chambers provide measurements for a limited area.</p>
Geochemical Monitoring of Shallow Groundwater	<p>Description: Geochemical sampling of shallow groundwater above CO₂ storage reservoir to demonstrate isolation of the reservoir from USDWs. Chemical analyses may include pH, alkalinity, electrical conductivity, major and minor elements, dissolved gasses, tracers, and many other parameters. Sensor probes/meters, as well as titration test kits, can be used to test/sample in the field.</p> <p>Benefits: Mature technology, samples collected with shallow monitoring wells. Sensors may be inserted into the aquifer. Address major regulatory concern regarding migration reaching USDWs, and may have value in responding to local concerns, which typically elevate concerns about groundwater.</p> <p>Challenges: Significant effort for potential lack of significant results. Reactive transport modeling of CO₂ migration shows that signal may be retarded and attenuated so that high well density and long sampling periods are required to reach an insignificant result. Many factors other than fluids from depth can change or damage aquifer water quality, and detailed assessment of aquifer flow system may be needed to attribute a change to signal either to migration or to other factors. Gas solubility and associated parameters (pH, alkalinity) are pressure sensitive, so that obtaining samples representative of the aquifer fluids requires careful sampling. Carbon isotopes may be difficult to interpret due to complex interactions with carbonate minerals in shallow formations.</p>
Surface Displacement Monitoring (Includes Remote Sensing)	<p>Description: Monitor surface deformation caused by reservoir pressure changes or geomechanical impacts associated with CO₂ injection. Measurements made with satellite-based radar (SAR/InSAR) and surface- and subsurface-based tiltmeters and GPS instruments. Data allow modeling of injection-induced fracturing and volumetric change in the reservoir.</p> <p>Benefits: Highly precise measurements over a large area (100 km x 100 km) can be used to track pressure changes or geomechanical impacts in the subsurface associated with plume migration. Tiltmeter technology is mature, and has been used successfully for monitoring steam/water injection and hydraulic fracturing in oil and gas fields. GPS measurements complement InSAR and tiltmeter data.</p> <p>Challenges: Tiltmeters and GPS measurements require surface/subsurface access and remote data collection. InSAR methods work well in locations with level terrain, minimal vegetation, and minimal land use, but must be modified for complex terrain/ varied conditions. Surface displacement responds also to groundwater withdrawal and recharge and to non-injection related process such as local to regional subsidence and uplift. Movement may not indicate risk, must be coupled with complex 3-D geomechanical models to make results actionable.</p>
Ecosystem Stress Monitoring (Includes Remote Sensing)	<p>Description: Satellite imagery, aerial photography, and spectral imagery are used to measure vegetative stress resulting from elevated CO₂ in soil or air. Ground-based study is required to develop understanding of signal to train the image processing and validate anomalies detected.</p> <p>Benefits: Imaging techniques can cover large areas, at relatively high frequency and low cost, and image processing can be automated. Vegetative stress is proportional to soil CO₂ levels and proximity to CO₂ release.</p> <p>Challenges: Detection only possible after sustained CO₂ emissions have occurred. Shorter duration release may not be detectable. Natural variations in site conditions make it difficult to establish reliable baseline. Changes not related to CO₂ release can lead to false positives. Variable sensitivity of vegetation to CO₂ and small areas of focus release can lead to missed signal.</p>

Examples of some of the tools and approaches for measuring soil gases are described below. Flux accumulation chambers consist of an open-bottom chamber placed on the soil surface and designed to collect gas emanating from soil pores. Monitoring a large area requires installation of flux accumulation chambers at multiple sampling locations. Captured soil gas is circulated through the accumulation chamber to an infrared gas analyzer (IRGA), and the rate of change of CO₂ concentration within the chamber is used to calculate the local flux of CO₂ from land to air. Subsurface access can be accomplished by drilling boreholes and installing small diameter tubing to make wells, by hammering in or inserting one-time or semi-permanent probes, or by excavating or horizontal drilling of various geometries of pits or trenches. Gas can be pumped from wells (e.g., by using a peristaltic pump), or sensors can be installed in place. Gas samples can be analyzed in the field or transported to the lab and analyzed using IRGAs, gas chromatography (GC), and/or mass spectrometry. Instruments such as fiber optic cables that measure CO₂ concentration and isotopes in place are being developed for geologic storage applications; such instruments are intended to be semi-permanently deployed. In all cases, the design should assess the interaction of the soil gas and atmosphere, as disturbance can create release from the surface into the measuring chamber and damage the soil's ability to retain gasses introduced from depth.

An additional soil-gas monitoring technique can include a calibrated sensor and a handheld meter display for a single time-series sampling event to measure key constituents such as CO₂, O₂, H₂S, and VOCs. The sensor can provide a good indication of CO₂ presence in the sample, but cannot typically read greater than five percent CO₂. For more accurate measurements and analysis that can detect above a certain threshold of CO₂ concentration, it is good practice to submit soil-gas samples in accordance with ASTM International standard procedures to a certified laboratory for GC analysis. The GC should be calibrated to measure the following: CO₂, O₂, N₂, hydrogen (H₂), carbon monoxide (CO), CH₄, ethane (C₂H₆), and ethylene (C₂H₄). These constituents provide good indicators and relationships of characterizing the sample to determine if or how the soil-gas sample has been impacted by the presence of CO₂.

Soil-gas measurements have been conducted during international projects not funded by DOE. Soil-gas concentrations were measured as part of a monitoring program at the In Salah storage project in 2004 and 2009 (Jones et al., 2010). In-situ gas concentrations (CO₂, CH₄,

O₂, CO, and H₂S) were measured using a soil-gas probe and electrochemical or IR detectors, and CO₂ fluxes were measured with accumulation chambers. Slightly elevated levels of CO₂ flux and concentration, suggesting a release, were observed near one of the pre-existing wells. That release was confirmed by direct observation of CO₂ emanating out of the wellhead, and the well was subsequently sealed and abandoned. Also, soil-gas CO₂ concentrations were measured at the CO₂CRC Otway project using a direct-push soil-gas probe and laboratory analysis of the collected gases (Schacht et al., 2010). Soil-gas CO₂ concentrations varied over three orders-of-magnitude during the initial baseline and subsequent assurance monitoring surveys. A combination of CO₂ and helium (He) concentrations, as well as carbon isotope analyses, was used to determine that the source of soil-gas CO₂ fluctuations was natural decomposition of organic matter at the site. This was confirmed by radiocarbon dating of selected samples.

Lessons Learned from the Field: Geochemical Monitoring in the Soil and Vadose Zone

Soil-gas measurements were one of the portfolio of monitoring methods carried out as part of the IEAGHG Weyburn CO₂ Monitoring and Storage Project in Saskatchewan, Canada, where CO₂ injection began in 2000 and is ongoing. Researchers measured CO₂ and radon concentrations, CO₂ flux, and CH₄/(C₂H₆+C₃H₈) ratios above the injection site using a steel probe, IRGA, and laboratory analysis of collected gas samples (Riding and Rochelle, 2005). Early efforts to establish the baseline highlighted the need to manage temporal variability. Spatial variability was also found to be large. All soil-gas measurements were found to be in the normal range for the site, and no evidence was found for escape of injected CO₂ from the storage reservoir by the research teams.

The MGSC Sugar Creek CO₂-EOR small-scale field project was initiated in the Sugar Creek Oilfield in Kentucky in 2009, and soil-gas CO₂ monitoring was put into place to test the extent of an actual, unplanned release. The release was identified visually and appeared to emanate from a flaw in a small CO₂ pipeline buried at a depth of approximately 1 meter below ground. Soil-gas CO₂ flux measurements were made with an array of accumulation chambers spread out on a radial grid centered on the surface expression of the release. Soil-gas CO₂ flux data clearly registered a leak from the pipeline; however, CO₂ concentrations exceeded the operating ranges of the monitoring instruments, which complicated the quantification of CO₂ flux (Wimmer et al., 2010).

Near-surface CO₂ flux measurements were obtained at the ZERT site during a simulated release test using small amounts of PFTs (Pekney et al., 2012) and a fiber sensor array (Soukup et al., 2014). Approximately 0.15 tonnes CO₂/day was released during the simulated test. PFT measurements used capillary adsorbent tube sampling and gas chromatographic analysis to track the movement of the CO₂ in the near-surface. The results provided valuable constraints for modeling CO₂ movement in the soil and vadose zone at ZERT. Figure 11 depicts the fiber sensor array that was deployed. The fiber sensor array uses a single temperature-tunable distributed feedback (DFB) laser. Light from this DFB laser is directed to one of the four probes via an inline 1×4 fiber optic switch. Each of the four probes is buried and allows the CO₂ to enter the probe through Millipore filters that allow the soil gas to enter the probe but keeps out the soil and water. Light from the DFB laser interacts with the CO₂ before it is directed back through the inline fiber optic switch. The DFB laser is tuned across two CO₂ absorption features, where a transmission measurement is made allowing the CO₂ concentration to be retrieved. The fiber optic switch then directs the light to the next probe where this process is repeated, allowing CO₂ concentration measurements at each of the probes to be made as a function of time. Background measurements indicate that the fiber sensor array can monitor background levels as low as 1,000 parts per million (ppm). Each of the four probes easily detected the elevated CO₂ concentration with values ranging over 60,000 ppm.

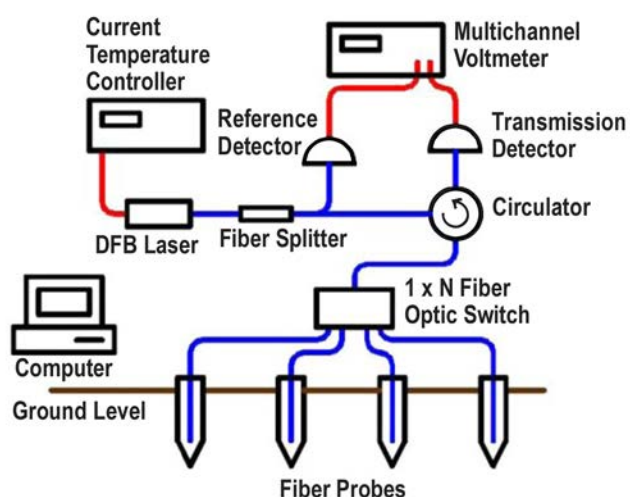

Figure 11: Schematic of 1 x 4 Fiber Sensor Array for Soil-CO₂ Detection

(Repasky et al., 2012)

Current and Ongoing Research: Geochemical Monitoring in the Soil and Vadose Zone

Soil-gas CO₂ flux measurements and vadose-zone gas sampling have been elements of monitoring plans at CO₂ injection projects to date. Figure 11 provides one possible sensor array setup for soil-gas CO₂ flux measurements. Soil-gas CO₂ flux measurements and vadose zone gas sampling are components of the monitoring program in the MGSC Illinois Basin – Decatur Project, Big Sky Carbon Sequestration Partnership (BSCSP) Kevin Dome Project, and SWP Farnsworth Unit Project. Vadose zone gas sampling is a component of the monitoring program in the PCOR Partnership Bell Creek Project. Soil-gas CO₂ flux measurements are a component of the post-closure monitoring program in the SECARB Citronelle Project.

Case Study 3.3 describes MGSC's experience collecting soil CO₂ flux data at the IBDP large-scale field project.

▶ See page 66

Case Study 3.4 summarizes soil gas monitoring study conducted by MGSC at the IBDP large-scale field project.

▶ See page 67

3.2.3.2 GEOCHEMICAL MONITORING OF SHALLOW GROUNDWATER

Geochemical monitoring of shallow groundwater may be carried out for several purposes: (1) to comply with expectations of the Class VI permit; (2) to provide assurance to local stakeholders that injected CO₂ has not been released to near-surface formations; (3) as part of an accounting protocol to demonstrate that CO₂ is not migrating out of the storage reservoir through the groundwater and into the atmosphere; and (4) to assure local landowners that geologic storage is not affecting residential drinking water or livestock water sources. Monitoring techniques can be designed to look for gas phase CO₂, or CO₂ speciation from dissolving into water, such as dissolved CO₂, bicarbonate or carbonate ions, indicators of speciation such as a decrease in pH, or indicators of mineral interactions with CO₂, such as mobilization of reactive metal cations, alkalinity, and elevated electrical conductivity. In some cases, lifting brine into USDWs may be a principle concern, in which case major and minor ion species will become a focus. In other cases, trace components of the injected CO₂ or phases present in the reservoir (e.g., CH₄) may be a selected tracer.

Specifically, geochemical measurements may include pH, alkalinity (both lowered by dissolution of CO₂), electrical conductivity, and various cation (e.g., Na⁺, Ca²⁺, Mg²⁺, Fe²⁺, Fe³⁺) and anion (e.g., HCO₃⁻, CO₃²⁻, Cl⁻, SO₄²⁻) compositions. Direct analysis of dissolved aqueous CO₂ concentrations can be accomplished in pumped water samples using volumetric expansion (Vesper and Edenborn) and non-dispersive infrared analytical approaches. In addition, C, H, and O isotopic analyses may be carried out; dissolved inorganic carbon may be measured; and other anion and tracer analyses may be conducted.

It is important to design a groundwater monitoring program to meet specific needs of the site with respect to the CO₂ injection. Groundwater systems in many areas are dynamic and respond to many changes in recharge and usage that are unrelated to the CO₂ injection at depth. Good design will allow a monitoring program to focus on the constituents that meet program needs without being triggered by other changes in the groundwater system. A combination of a detailed characterization of the hydrology of the groundwater system (recharge, discharge, and gradient, cross-formational flow, etc.); the chemistry and chemical variability (baseline) of aquifer water or landowner water wells; characterization of the aquifer mineralogy; and especially characterization of components that either generate or interact with dissolved CO₂ species is required. A series of batch reaction tests with CO₂ in the lab and/or in-situ small injection/extraction of groundwater saturated with dissolved CO₂ (push-pull test) may be useful to constrain models (C. Yang et al. 2013c). A reactive transport model can be used to determine the spacing of monitoring wells required to detect migration of CO₂ into the aquifer at a certain threshold within a certain timeframe (C. Yang et al., 2012).

Typical shallow groundwater monitoring wells are less than 100 meters deep, though deeper wells may be required in locations where potable water sources occur at greater depths. For example, many places in the Rocky Mountains have potable water as deep as 900 meters. It is important that good monitoring well design and operation be used to avoid cross-contamination of aquifers. Long screened and sand-packed intervals may be useful in sampling the aquifer comprehensively; however, detection threshold and the interaction with a heterogeneous aquifer and a buoyant gas should also be considered. Gas-specific sampling methodologies must be used as CO₂ solubility is both temperature- and pressure-dependent; poor sampling techniques that do not standardize for these parameters can allow noise to interfere with the signal. Methods involving flow-through cells that collect headspace gas or downhole sampling devices that transport fluids in pressurized sample containers to the surface may be valuable.

Lessons Learned from the Field: Geochemical Monitoring of Shallow Groundwater

Design and operation of a groundwater monitoring program at the SECARB Cranfield Project revealed a number of previously unexplored issues that highlight the difficulties in using groundwater sampling data for a definitive determination of no leakage from a storage reservoir. At Cranfield, an array of water-supply wells (one at each injection well) completed at depths of 100 to 125 meters over the plume area were sampled quarterly from 2009-2015 and conventional field parameters, major and minor elements, and selected stable isotopes were analyzed (C. Yang et al, 2013b). No trends indicative of release were detected in this array. However, observation and analyses discussed below showed that the data was insufficient to make a definitive (ie, high level of confidence) determination of no leakage. The principal value of these data was documentation of the variability of the hydrogeologic system.

Risk-assessment modeling revealed that, at Cranfield, brine was unlikely to be lifted to surface and CO₂ would be the fluid that should be considered as potentially migrating into freshwater aquifers (Oldenberg, et al, 2015) To assess the geochemical signal that would be detected should CO₂ migrate into freshwater, a field push-pull test simulating the introduction and dissolution of CO₂ was conducted in a freshwater sandstone reservoir at 130 meters below surface (C. Yang et al., 2013a). The test showed that release detection would depend on measurement of pH or dissolved inorganic carbon (DIC) above background variability; no unique or diagnostic reaction products were observed.

Reactive transport modeling was done of a well-failure scenario in which CO₂ was leaked into the aquifer and dissolved. The model included the signal observed by the controlled release of dissolved CO₂ and the ambient variability derived from the quarterly monitoring. Modeling showed that a large array of wells several times more dense than the array used would be needed to intersect a geochemical signal produced by moderate CO₂ leakage into an aquifer, even after long periods of leakage (C. Yang et al., 2015a). Therefore, even though no leakage was detected, it was not possible to definitively state, based only on groundwater data collected during the six year study that no leakage had occurred. Modeling suggests that this is a likely general case for many aquifers.

One additional complication in directly monitoring the groundwater at Cranfield is that fresh groundwater resources occur in numerous hydrologically isolated zones. Sampling in any one zone could miss significant release into another zone. If wells were perforated in several zones and the results comingled, fluids from a

contaminated zone would be diluted and the signal lost. In addition, the coring and logging program showed heterogeneity in distribution of flow units that would require in-depth hydrologic assessment to design a robust monitoring program that could intercept major flow paths. Another complication is that the Cranfield study area lies along a surface-water divide, and the potentiometric surfaces of shallow groundwater zones are nearly flat so that no clear flow direction could be established.

This assessment shows that very dense well arrays of multilevel samplers may be needed to reduce the potentially large uncertainty in a determination of no leakage based solely on groundwater sampling.

Shallow groundwater monitoring conducted at the Scurry Area Canyon Reef Operators Committee (SACROC) oilfield in Texas, where CO₂-EOR has been conducted for more than 35 years, indicates that carbon isotopes may be used for identifying the source of CO₂ in shallow groundwater systems (Romanak et al., 2010b). However, a site-specific context is necessary to understand the complex dynamics of carbonate dissolution in shallow groundwater aquifers. Influential factors may include mixing of groundwater with underlying saline waters, leaching of historically produced brine and other liquids into freshwater aquifers from unlined surface pits, temporal geochemical variations related to pumping and local irrigation practices, and site-specific geochemical reactions that affect shallow groundwater chemistry (Romanak et al., 2008).

Shallow groundwater monitoring at the CO₂CRC Otway site was initiated in June 2006, nearly two years prior to the onset of CO₂ injection at the site. A baseline was established by monitoring seasonal water levels and bi-annual groundwater chemistry in a shallow aquifer that lies approximately 2,000 meters above the CO₂ storage reservoir (Hortle et al., 2010). Pre-injection baseline measurements, when compared with injection and post-injection monitoring results, indicated no significant fluctuations in the shallow aquifer chemistry as a result of CO₂ injection.

A study by Meier and Sharma (2015) documents the utility of using stable carbon isotopes to track potential leakage of CO₂ in an enhanced coal bed methane (CBM) recovery site run by Consol Energy Inc. in West Virginia. This study measured carbon isotopes from produced natural gas, shallow groundwater, and soil vadose gas

at a CBM recovery site where CO₂ was injected into the Upper Freeport coal bed intermittently from Sept. 2009 to Dec. 2013. The $\delta^{13}\text{C}$ values for the soil vadose gas, groundwater and produced CO₂ had very distinct carbon isotope signatures (highlighting the importance of characterization of baseline measurements in order to strengthen the use of $\delta^{13}\text{C}$ as a natural tracer in the system). The study was able to monitor the CO₂ plume movement in the coal bed over the study area, and also illustrated that over the study period, no significant leakage of injected CO₂ from the coal bed was observed in the overlying formations or soil vadose zone.

In tandem with soil-gas studies, controlled release experiments can be very helpful in understanding both the risk and the signal to be detected should CO₂ or brine migrate to shallow groundwater. For example, groundwater monitoring has been conducted during controlled CO₂ release experiments at the ZERT field site in Montana. Carbon dioxide was injected through perforated pipe buried approximately 2 meters below the surface for a one-month period during the summer of 2008. Water samples were collected from 10 monitoring wells installed 1 to 6 meters from the injection pipe (Kharaka et al., 2010; Apps et al., 2011). A decrease in pH, increase in total alkalinity, increase in electrical conductance, and major increases in calcium (Ca), iron (Fe), magnesium (Mg), and manganese (Mn) were observed following CO₂ injection (Figure 12). This effort helped verify that changes in groundwater can be observed in the event of a CO₂ migration out of the storage reservoir. Other shallow groundwater controlled release experiments have been conducted at Plant Daniel (Trautz et al., 2012) and the Brackenridge field site (C. Yang et al., 2014b).

Case Study 3.5 describes MGSC's shallow and deep groundwater compliance monitoring at the IBDP large-scale field project.

▶ See page 68

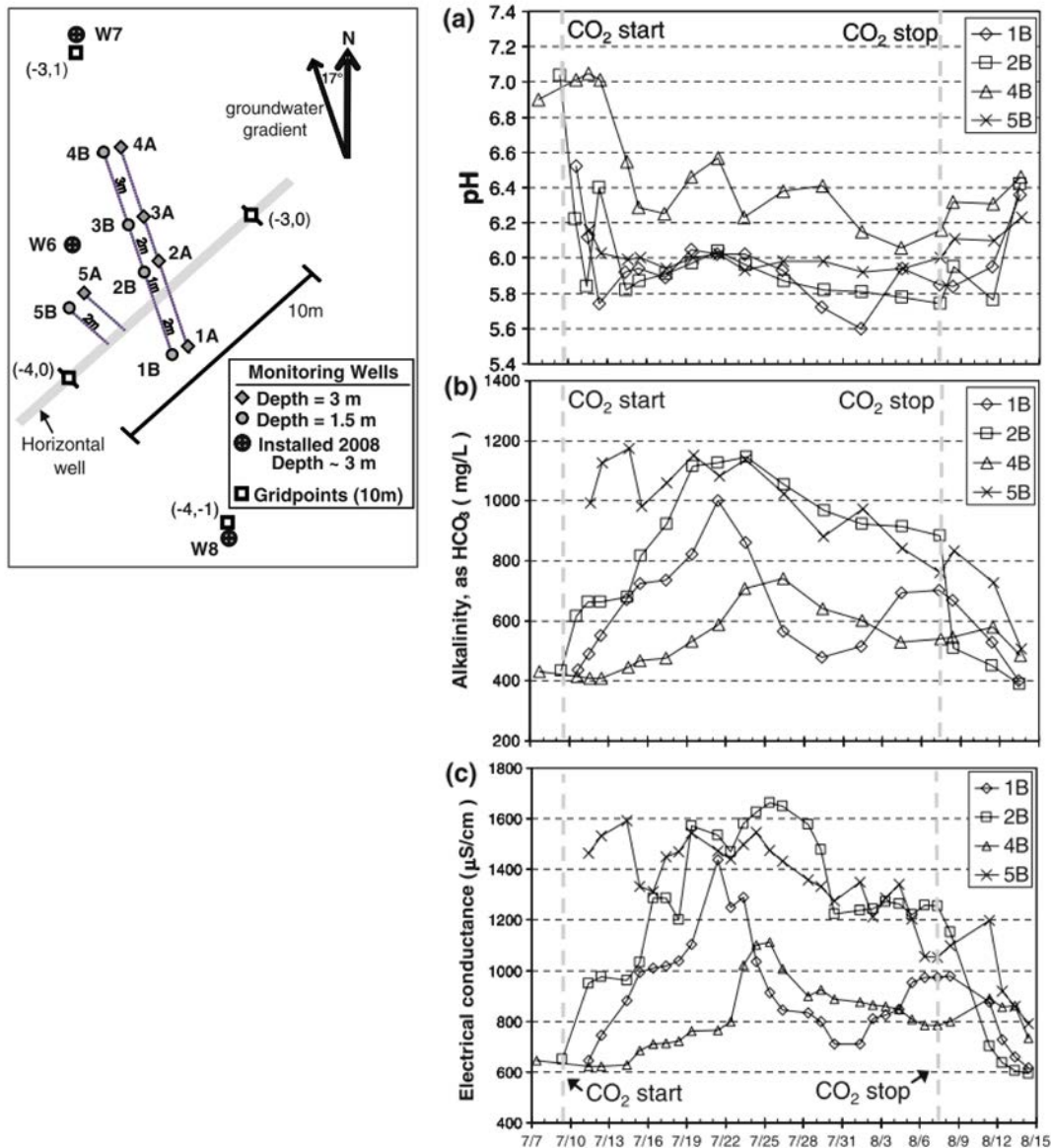

Figure 12: Groundwater pH, Alkalinity, and Electrical Conductance Values Measured at the ZERT Site; Monitoring Well Configuration is Also Shown

(Kharaka et al., 2010)

Current and Ongoing Projects: Geochemical Monitoring of Shallow Groundwater

One of the current research advances for shallow groundwater monitoring is developing semi-permanent instrumentation that can be deployed to measure a variety of chemical parameters as indicators of CO₂ and/or brine release into overlying formations. Such techniques may lower costs created by an expectation of repeated sampling over long durations.

Intelligent Optics Systems is developing a multi-parameter system for the highly sensitive and accurate detection of CO₂ in groundwater (Alonso, 2015). The stand-alone system includes novel distributed fiber-optic sensors for CO₂, pH, and salinity, as well as a commercially available distributed sensor for temperature. The sensors are fabricated by coating optical fibers with chemically sensitive indicator-doped polymers, thus creating a sensor the entire length of the optical fiber that is capable of covering large areas in distances of a few thousand meters. The project involves

developing two novel sensitive claddings for salinity and pH sensing. Once developed, optical cables sensitive to each parameter will be produced. Those cables will be combined with a CO₂-sensitive cladded fiber, as well as an off-the-shelf, fiber-optic temperature sensor to produce a real-time monitoring network. Field deployment of the first generation system has occurred. A second-generation system and a sensitivity study are underway.

DOE is developing and demonstrating a suite of protocols and tools for new types of geochemically based monitoring strategies for groundwater systems and developing a statistical understanding of natural groundwater variability in CO₂ storage systems. Natural geochemical tracers (e.g., isotopic, chemistry, trace elements, etc.) are being used to monitor groundwater systems. In addition, Jain et al. (2011) are developing a miniature, ruggedized, remotely operated laser system for Laser-Induced Breakdown Spectroscopy (LIBS) analysis (Figure 13). LIBS can be applied for real-time elemental and isotopic analyses of solid, liquid, and gas samples. It represents a significant advance over conventional techniques, such as mass spectrometry, because it provides rapid and direct chemical characterization without extensive sample preparation procedures. Current research efforts are focused on the development of a high-pressure, high-temperature laser system for groundwater monitoring, CO₂-release detection, in-situ tracer detection, and isotope measurements.

Nanomaterial enabled fiber optic based sensor probes are also being developed by DOE for direct CO₂ and CO₂ proxy (e.g. pH) measurements in groundwater systems. Advantages of fiber-optic based probes include the ability to remotely interrogate within geological systems without the need for electronics, wires, or instrumentation at the sensing location as well as compatibility with distributed interrogation techniques that enable mapping out parameters as a function of depth or position within a geological system. Key successes by the team to date include the direct monitoring of CO₂ at relevant concentrations using metalorganic framework and plasmonic nanoparticle incorporated metalorganic framework materials (Chong et al. 2016; Chong et al.; 2015, Kim et al.) . In addition, new sensing probes for solution phase pH were demonstrated based upon metal nanoparticle incorporated oxides such as Au/silica and related systems that are anticipated to be more robust under high temperature and harsh environment conditions than traditional organic based pH indicators (Wang et al., 2015a; Wang et al., 2015b; and Elwood and Ohodnicki). Continued work is focused on further improving the nanomaterial enabled sensor probes for geological environments by reducing cross-sensitivity to other chemical species as well as to other solution phase parameters such as ionic strength and concentrations of various ionic species.

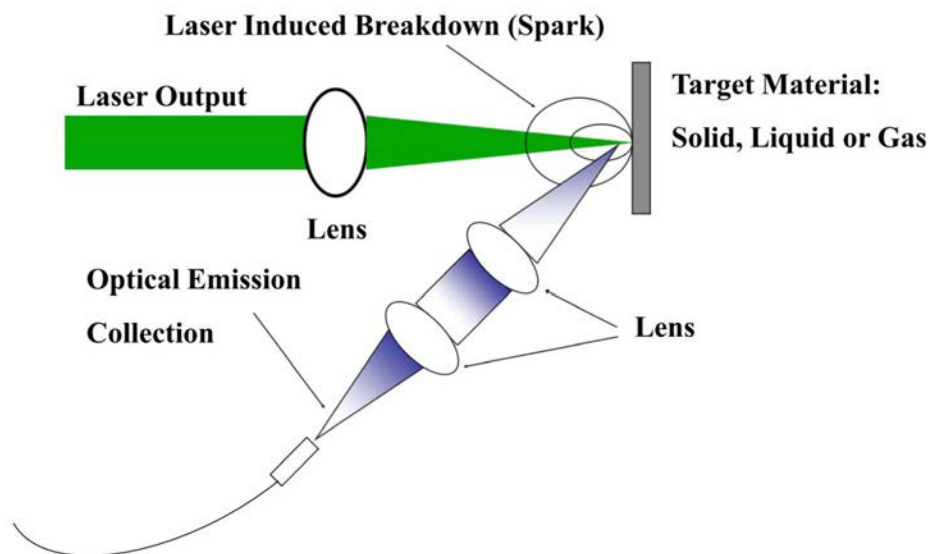

Figure 13: Schematic of LIBS
(Source: Jain et al., 2011)

The New Mexico Institute of Mining and Technology is developing a robust pH sensor for in-situ monitoring of subsurface fluids (Liu, 2016). The pH of the fluid will reflect dissolved CO₂. The downhole pH/CO₂ sensor will be developed to resist high pressures, high temperatures, and high salinity. Materials development includes the use of a metal-oxide pH electrode with good stability and the understanding of different factor's effects on the performance of the electrode, after which sensor performance under high pressures, temperatures, and salinity conditions will be evaluated. Additional performance evaluations of the sensor will be carried out using CO₂/brine core-flooding tests, and a data-acquisition system will be developed to enable pH and CO₂ presence to be determined in-situ.

3.2.3.3 SURFACE DISPLACEMENT MONITORING

Injection of CO₂ into a reservoir may cause an increase in the reservoir pressure, which may result in small displacements of the ground surface above the reservoir. Highly precise surface displacement measurements, including data acquired with Interferometric Synthetic Aperture Radar (InSAR), tiltmeters, and global navigation satellite systems (GNSSs), can be used to monitor this deformation. Surface displacement data can be inverted to show the footprint of pressure changes in the subsurface. This footprint includes the CO₂ plume plus a region in the brine beyond the plume where pressures have been changed due to injection operations. Geomechanical modeling is used to correlate surface displacement data with the location and distribution of pressure in the subsurface. Factors such as groundwater withdrawal and recharge or local/regional subsidence must be considered (Dixon and Romanak, 2015). Extensive processing is needed to extract signal and invert it to subsurface pressure change.

SAR/InSAR is a satellite-based technique that measures millimeter-scale displacements of the Earth's surface by recording microwaves as they are reflected off permanent, solid features on the ground. The amount of surface displacement due to increase in pressure or geomechanical impacts resulting from CO₂ injection is typically small; uplift related to CO₂ injection at the In Salah storage site, for example, was recorded at approximately 3 to 5 mm per year. Large areas, up to 10,000 km², can be imaged in a time-lapse manner to evaluate surface displacement occurring over a given time period. The frequency of the time-lapse monitoring depends on how often the satellite passes over the area of interest. The satellite used at In Salah, for example, provided a revisiting time of 12 days. Permanent Scatterer InSAR (PSInSAR) may reach an accuracy of 1 mm/year for long-term monitoring given a

sufficient number of high-quality images (Ringrose et al., 2009). InSAR methods work well in locations with level terrain, minimal vegetation, and minimal land use, and require adaptive techniques, such as the installation of permanent reflectors, when these conditions are not met.

A tiltmeter is an instrument that operates like a carpenter's level and is able to measure extremely small (one part in a billion) changes in strain, either at the Earth's surface or at depth. Tiltmeters are commonly deployed to monitor oilfield operations, including water flooding, CO₂ flooding, and hydraulic fracturing. Measurements are typically collected remotely via radio or satellite. A widespread array of tiltmeters may be required to accurately measure surface deformation associated with pressure in the subsurface.

GNSS allows the precise determination of a location anywhere on or above the Earth's surface. Both the U.S. GPS and the Russian Global Navigation Satellite System (GLONASS) are currently available for commercial applications. Efficient receivers, combined with enhanced signal processing techniques, allow remote, continuous operation of GPS stations with accuracies of 1.5 mm or less. A Surface Tilt Monitoring (STM) array can measure relative changes in elevation with sub-millimeter accuracy over a large area, whereas high-precision GPS measurements provide absolute elevation changes with millimeter-scale accuracy for the region of interest. GPS measurements are typically employed to complement long-term tiltmeter and InSAR monitoring surveys.

Surface deformation monitoring techniques require permitting and site access for equipment installation in the field (Hamling et al., 2011). Shallow boreholes are required for installation of tiltmeters, InSAR corner reflectors, and GPS instruments. The long-term reliability of tiltmeters can be affected by drift, which can be mitigated by calibration to other displacement measurements and advanced data-processing methods.

Lessons Learned from the Field: Surface Displacement Monitoring

A very significant application of InSAR was conducted at the In Salah project in Algeria (Figure 14). The ground surface at In Salah is rocky desert, which has a high and stable coherence suitable for InSAR. Analysis of interferometric data through time shows growth of spatially delineated uplifts overlying the injection wells at rates of up to 5 mm/year (Mathieson et al., 2011), with cumulative uplifts in excess of 20 mm.

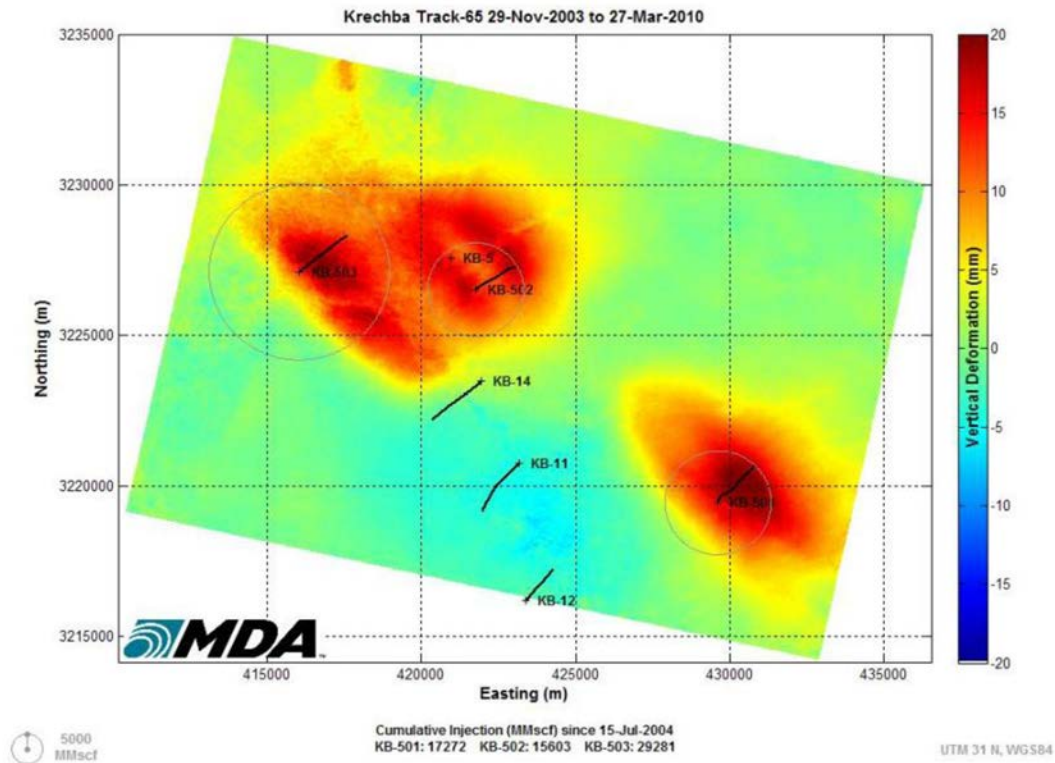

Figure 14: Satellite Image of Cumulative Surface Deformation at Krechba (In Salah) Due to CO₂ Injection
(Mathieson et al., 2011)

Current and Ongoing Research: Surface Displacement Monitoring

The Midwest Regional Carbon Sequestration Partnership (MRCSP) is evaluating the potential of InSAR as a monitoring technology to determine if it has application for detecting ground surface movement (e.g., uplift) as a result of the injection of CO₂ within closed carbonate reef reservoirs. The technology is being tested in Northern Michigan, which consists of agricultural areas and forests, to look for any quantifiable, small-scale, surface-level changes related to injection of CO₂. This project is leveraging existing EOR operations located within a geologic setting known as the Niagaran Pinnacle Reef Trend within the Michigan Basin. The individual fields are part of the Silurian age pinnacle reefs, occur at subsurface depths of approximately 1,700 meters, and are closed reservoirs with containment provided by thousands of feet of low permeability hard carbonate and evaporite layers.

The observations to date have shown no discernible change in the surface elevation in response to injection operations even after the bottomhole pressure in the main test field has increased from approximately 800 to 3,200 pounds per square inch (psi). The observed behavior was confirmed using a 3-D fluid flow simulator with a geomechanics module to model the pressure increase and poro-elastic response within the reservoir and overburden during injection (Figure 15). Using the measured bottomhole pressure data during MRCSP injection operations, the model showed that the total surface uplift would be less than 1 mm, which is not measurable by InSAR. While measurable changes in elevation in response to injection do not occur at this site, the MRCSP large-scale injection test provides an opportunity to gain practical experience in applying InSAR for CCS monitoring necessary to build capacity for future commercial-scale deployment.

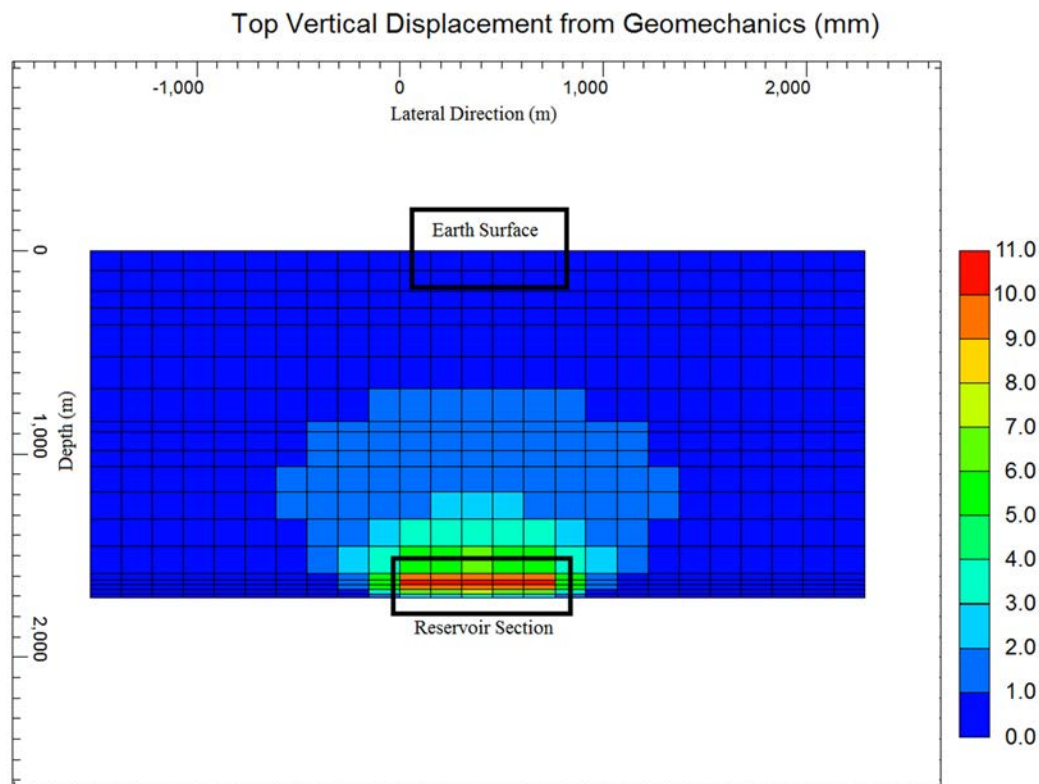

Figure 15: Schematic of Reservoir and Overburden Deformation for Conservative Scenario
(Predicts the surface uplift will be less than 1mm when reservoir pressure increases from 780 psi [beginning of MRCSP phase] to 4,000 psi; color-coded scale in mm).

3.2.3.4 ECOSYSTEM STRESS MONITORING

Plants are susceptible to stress caused by elevated levels of CO₂ in the soil, and measurements of vegetative stress can be used as an independent indicator of possible CO₂ release from the subsurface. Vegetative stress can be measured by aerial photography, satellite imagery, and spectral imagery. Initial surveys are required to establish baseline conditions, including seasonal changes that take place at a particular site, as well as natural variations in temperature, humidity, and light and nutrient availability at the site. Once the baseline is established, anomalous vegetative stress may be observed. Ground-based training during baseline collection and validation and attribution of anomalies detected is required.

Hyperspectral imaging collects and processes radiation across a broad portion of the electromagnetic (EM) spectrum, typically including wavelengths from 400 to 900 nanometers. This includes the high-absorbance region in the visible spectrum associated with chlorophyll absorbance, and high reflectance in the near-IR region that is typical of spongy leaf tissues. Spectral imaging has the ability to detect changes in light reflectance and

absorption that occur in vegetation that is struggling. Multispectral imaging may be simpler and less costly, and it affords continuous daytime operation in both clear and cloudy weather (Rouse et al., 2010). Whereas hyperspectral imaging collects a continuous spectrum of wavelengths, multispectral imaging collects discrete spectral bands. Spectral imaging sensors may be airborne, satellite-mounted, or handheld.

Lessons Learned from the Field: Ecosystem Stress Monitoring

Hyperspectral imaging was used to detect vegetative stress related to CO₂ release at the ZERT facility in Montana (Male et al., 2010). A controlled near-surface CO₂ release experiment was conducted during the growing season at the ZERT facility to simulate a CO₂ release scenario. Simultaneously, aerial imagery was collected to obtain a time series used to identify and characterize the simulated CO₂ release prior to, during, and after the three-week CO₂ release. A spectral indicator of vegetation stress was developed that could quantify the CO₂ stress signal and chart vegetation health trajectories over the course of

the CO₂ release experiment (Figure 16). Results suggest that there was a cumulative vegetation stress response followed by a possible vegetation recovery and that aerial hyperspectral imaging may be a plausible method for detecting CO₂ release from geologic storage sites. Similar results were obtained at the Australian Ginninderra site (Feitz et al., 2014) during aerial hyperspectral imaging studies.

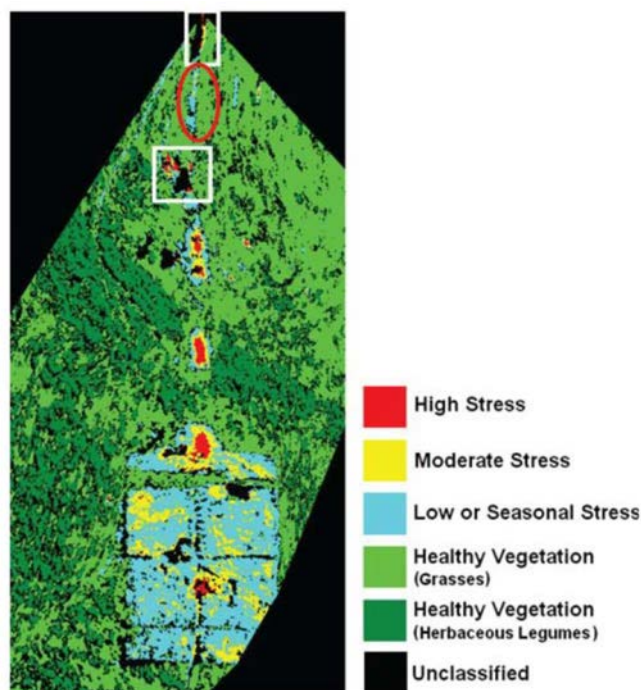

Figure 16: Aerial Hyperspectral Imagery Collected at the ZERT Facility 27 Days After CO₂ Injection, 2008

(Male et al., 2010)

Researchers at the MGSC Validation Phase Sugar Creek site in Kentucky tested several monitoring techniques, including aerial hyperspectral imaging, during a real, short-duration CO₂ release from a buried pipeline (Wimmer et al., 2010). Hyperspectral imaging was found to be ineffective at locating the release; longer duration releases may be more readily identified by hyperspectral methods because of cumulative effects of CO₂ on vegetation.

Current and Ongoing Research: Ecosystem Stress Monitoring

As described above, ecosystem stress monitoring research is focused on field-testing of current tools. The Carbon Storage Program is not currently developing technologies to address ecosystem stress.

3.3 SUBSURFACE MONITORING

Subsurface monitoring of CO₂ storage projects has several objectives, including monitoring the evolution of the dense-phase CO₂ plume, assessing the area of elevated pressure caused by injection, and determining that both pressure and CO₂ are within the expected and acceptable areas and migrating in a way that does not damage resources or the integrity of the storage complex. Tracking the movement of an injected CO₂ plume in a deep geologic formation can include defining the lateral extent and boundaries of the plume as expected by EPA under Class VI rules to show that the plume remains in the AoR. In addition, measurements of the area and saturation of CO₂ over time can be used to validate numerical models, which may increase their reliability in terms of predicting the long-term stability of the CO₂ plume. Additional measurements may also be planned to track plume stabilization during the post-injection period. EPA also requires measurement of pressure changes in the reservoir as part of a Class VI permit. Most techniques and tools used for subsurface monitoring were originally developed to characterize the geologic framework and rock and fluid properties of hydrocarbon producing reservoirs and can play this role in a CO₂ storage setting.

3.3.1 REGULATORY REQUIREMENTS

Per EPA regulations (40 CFR 146.90 – Testing and Monitoring Requirements), the owner or operator of a Class VI well is required to perform specific monitoring activities focused on the subsurface. The owner or operator must verify that the geologic storage project is operating as permitted. A pressure fall-off test is to be performed at least once every five years, unless more frequent testing is required by EPA based on site-specific information. In addition, the owner or operator is to monitor the extent of the injected CO₂ plume and the presence or absence of elevated pressure (e.g., the pressure front) by using either direct methods in the injection zone(s) or indirect methods (e.g., seismic, electrical, gravity, or electromagnetic surveys and/or downhole CO₂ detection tools), unless EPA determines, based on site-specific geology, that such methods are not appropriate. On a yearly basis, a demonstration of injection well mechanical integrity is required to determine the absence of significant fluid movement impacting USDWs. Either an approved tracer survey such as an oxygen-activation log or a temperature or noise log satisfies this requirement. Mechanical integrity testing is described in more detail in the Operations for Geologic Storage Projects BPM.

3.3.2 SUBSURFACE TOOLS AND APPROACHES

Deep subsurface monitoring is carried out using an extensive range of tools. Some tools access the subsurface via wells and can probe an area around the well in high resolution; other tools are deployed at the surface and use geophysical properties to measure fluid and rock properties at a distance, and combined instruments deployed such as using two or more wells (crosswell) or one or more wells and the surface can be used. Data can be collected and processed to image

one-dimension (near well), to image planes, or 3-D volumes. Wireline-conveyed logging tools can measure rock, fluid, and well-construction properties. Wells can also be used for subsurface fluid sampling. Examples of geophysics are seismic methods and gravity and electrical techniques. These tools and techniques are summarized in Table 5 and described in greater as follows. Subsurface monitoring programs may use a combination of these tools, depending on the specific geologic conditions and uncertainties at a given CO₂ storage site and the determinations required from the monitoring program.

Table 5: Summary of Subsurface Monitoring Techniques

Subsurface Monitoring	
Monitoring Technique	Description, Benefits, and Challenges
Wireline Deployed Well Logging Tools	<p>Description: Mature technology in which tools lowered into wells on wireline cables (so that the tool is in communication with the surface) are slowly moved up the well collecting data designed to monitor the condition of the wellbore and changes in fluids in the near-wellbore environment. Examples of logs used in geologic storage monitoring include acoustic (sonics), resistivity, borehole diameter logging, and pulsed neutron capture.</p> <p>Benefits: Commercial technology used to assess the condition of the well casing and cement and changes in near-wellbore fluid or formation composition. Under favorable conditions, log response may be highly sensitive to CO₂ outside the wellbore. No need to perforate well to detect CO₂.</p> <p>Challenges: Area of investigation limited to near the wellbore. Sensitivity of tool to fluid change varies; only under optimum conditions are tools sensitive to dissolved CO₂ or changes in mineralogy. Working fluids in wells may affect log results. Logging requires wells that penetrate the interval of interest and mobilization costs may be substantive, limiting repeated surveys. If a well is perforated in an area charged with CO₂ access, the well requires pressure management. Both wireline and well casing may corrode, especially in the presence of CO₂, requiring management via metallurgy or corrosion inhibition.</p>
Wellbore Deployed Pressure and Temperature	<p>Description: A large array of gauges is available to measure pressure and temperature. Technology is mature. Gauges are deployed at wellhead and can be permanently installed on casing, semi permanently deployed on tubing, or intermittently emplaced on slickline. Wireline communications are standard with the casing and tubing deployments; the intermittent emplacement may either be on wireline or use internal memory and be retrieved. Gauges may be deployed both on injection wells and on monitoring wells distant from injection intervals.</p> <p>Benefits: Reservoir pressure is a key parameter in the EPA UIC Class VI Program, and because of the complex temperature and pressure effects on fluid density, direct measurements at the reservoir may be needed to augment and calibrate standard wellhead pressure measurements. Measurements of reservoir response to changes in injection pressure is a mature tool for assessing fluid flow and hydrologic properties and is a key input for history-matching simulation models.</p> <p>Challenges: Gauges must be in communication with the reservoir. If the gauge is run inside of the casing, then the well must be perforated and thus the entire well is potentially exposed to corrosive fluids, increased pressure, and potential changes in wellbore fluids that may alter monitoring technologies run from inside of it (e.g., seismic). Gauges run outside of casing are not retrievable, must be carefully placed to exclude cement between the gauge and the reservoir, and must have an umbilical back to the wellhead that is a potential leakage path</p>
Wellbore-Based Fluid Monitoring Tools	<p>Description: Geochemical sampling is required under EPA's UIC Class VI to quantify the composition of the injected fluid. Fluid sampling can also be conducted at wells distant from injection wells to assess breakthrough of CO₂ or rock-CO₂ water reactions using surface or downhole samplers.</p> <p>Benefits: Modeling the response of the reservoir to injection.</p> <p>Challenges: Assessing chemistry of CO₂-brine pore fluids in the rock matrix presents many challenges related to pressure and temperature dependence of solubility and the complexity of accurately sampling mixed density-mixed viscosity brine and CO₂ in the well construction.</p>

Table 5: Summary of Subsurface Monitoring Techniques (continued)

Subsurface Monitoring	
Monitoring Technique	Description, Benefits, and Challenges
Emerging Wellbore Tools	<p>Description: Emerging wellbore technologies include smart sensors for geologic storage monitoring applications and subsurface tracer applications. Tools include harmonic pulse testing of reservoirs, modular borehole monitoring, and novel tracers.</p> <p>Benefits: Demonstrate reservoir integrity through pressure response during pulse testing. The modular borehole monitoring (MBM) concept is a multi-functional suite of instruments designed to optimize subsurface monitoring. Geochemical changes associated with the interaction of injected tracers and supercritical CO₂ provide insight concerning migration of CO₂ through the reservoir.</p> <p>Challenges: Reservoir noise interference and signal-to-noise ratio may be an issue.</p>
Seismic Geophysical Methods	<p>Description: Seismic geophysical methods use acoustic energy to image the subsurface. Differences between the acoustic properties of CO₂ and other fluids enable the plume monitoring by seismic methods. Active seismic methods (surface seismic reflection, VSP, crosswell) require a source and receiver. Passive seismic methods use natural subsurface processes that emit acoustic energy from fracture development or slip on a fault.</p> <p>Benefits: Substitution of CO₂ for brine under many conditions creates a strong change in seismic velocity ideal for time-lapse quantification from pre-injection baseline (brine-filled) pores to pores partly filled with CO₂. Reflection seismic under the right conditions is useful both for time-lapse monitoring of a CO₂ plume and for identification of any out-of-zone CO₂ accumulation indicating a release. Surface seismic surveys can assess large areas and large thicknesses completely (as compared to point measurements). Borehole seismic (crosswell, VSP) surveys can provide higher-resolution imaging near or between wellbores. Passive seismic (microseismic monitoring) can be used to detect natural and induced seismicity, to map faults and fractures in the injection zone and adjacent horizons, and to track the migration of the fluid pressure front.</p> <p>Challenges: Repeatability of seismic survey needed for time-lapse surveys may be difficult under varying surface conditions. Geologic complexity and a noisy recording environment can degrade or attenuate surface seismic data and the presence of gas in baseline fluids can reduce detection of CO₂. Borehole seismic methods require a wellbore for monitoring, and for crosswell, the distance between wells containing the source and receivers may limit success of the survey due to source strength constraints. A comprehensive knowledge of reservoir geomechanical properties is needed to properly interpret microseismic events for migration of the pressure front.</p>
Gravity Methods	<p>Description: Use of gravity measurements to monitor changes in density of fluid resulting from injection of CO₂, which is substituted for brine or other reservoir fluids.</p> <p>Benefits: Gravity measurement provides a direct assessment of the parameter wanted, mass of CO₂, unlike all other measures, which are proxies and must be converted by modeling into an estimate of mass.</p> <p>Challenges: Technology is still maturing. Limited detection and resolution unless gravimeters are located just above reservoir, which significantly increases cost. Noise and gravity variations (tides, drift) need to be eliminated to interpret gravity anomalies due to CO₂.</p>
Electrical Methods	<p>Description: Based on the resistivity contrast between injected CO₂ and more conductive brine, can be used in time-lapse. Technology used in the oil and gas industry to detect hydrocarbons. Electrical methods used in geologic storage projects are (1) electrical resistance tomography (ERT) and electromagnetic (EM) tomography that images spatial distribution of resistivity in reservoir by measuring potential differences and (2) controlled-source electromagnetic (CSEM) surveys that measure induced electrical and magnetic fields.</p> <p>Benefits: Electrical techniques provide resistivity distribution in the subsurface, which can be interpreted to estimate CO₂ saturation distribution. Data resolution is dependent on electrode spacing for ERT techniques. Crosswell ERT is more sensitive to changes in near-wellbore resistivity. Surface-downhole ERT and CSEM measurements increase the lateral extent and provide data on CO₂ plume tracking. ERT and CSEM do not interfere with other subsurface monitoring techniques operating within the well casing (e.g., wireline logging, borehole seismic).</p> <p>Challenges: May not detect contrast between CO₂ and hydrocarbons. ERT, EM tomography, and CSEM surveys require non-conductive well casings and multiple monitoring wells. Deployment and inversion are less mature than other technologies.</p>

Monitoring of subsurface fluids, rocks, and wells can be conducted by locating instrumentation within wellbores to different depths or in arrays at or near the surface. Tools that are deployed within boreholes on wireline cables are commonly referred to as well logging tools. A subset of these tools assess the condition of the well itself and are known as well monitoring tools. Monitoring that uses acoustic energy to assess rocks and fluids in the subsurface are described as seismic tools; those that use gravity and electrical methods are referred to by those terms.

Many subsurface monitoring techniques were originally designed for oil and gas exploration and resource development, and have been recently adapted for use in CO₂ storage fields. Some technologies, such as well logging and reflection seismic imaging, have reached a highly sophisticated level due to many decades of utilization in the petroleum industry. A focus of many current R&D activities has been to adapt these methods to the specific requirements of CO₂ injection, storage, and long-term monitoring. Note that some of these subsurface monitoring technologies are available commercially and are being utilized in injection projects to identify formation characteristics and track CO₂ migration.

Many subsurface monitoring strategies for CO₂ injection can be optimized by collection of a baseline prior to injection, followed by time-lapse surveys. Surveys can then be subtracted during analyses to show changes between surveys attributed to the injection. Fortunately, many of the techniques used for subsurface monitoring are also used to characterize the storage complex, as well as the properties of the storage reservoir and confining zones prior to injection. These measurements can therefore be designed to become part of the baseline for measurements made after CO₂ injection begins.

Note that many subsurface monitoring techniques do not directly detect CO₂; rather, they detect changes in some other property, such as seismic velocity or electrical resistivity, which may then be interpreted to provide relevant information about CO₂ storage or movement. This requires extensive data processing and analysis. Measurements may not be adequate to completely describe the CO₂ in the reservoir; for example, extraction of saturation information from seismic surveys requires development of a rock physics model, which can prove challenging. Forward-modeling studies are often used to design an injection and monitoring program, and inverse-modeling studies are typically employed to analyze the collected data.

3.3.2.1 WIRELINE DEPLOYED WELL LOGGING TOOLS

Well logging technology is highly advanced, owing to development during decades of utilization in oil and gas exploration and production. In recent years, many well logging tools have been applied to subsurface monitoring of CO₂ in fields where CO₂ storage and/or CO₂-EOR operations are underway. Well logging consists of lowering instruments attached to an instrumented cable known as a wireline into a wellbore and as the cable is spooled, measurements made at the tool are transmitted to the surface where they are processed to yield data on the physical and chemical properties of a formations and their pore fluids. Examples of wireline logging tools include pulsed neutron tools (PNTs), acoustic, and resistivity logging tools. Metal casing interferes with some wireline measurements, so in conventional operations wireline logging is carried out before casing is installed (i.e., in openhole conditions). Well logging performed after casing is installed is referred to as cased-hole logging.

A number of standard well logging tools are used to characterize the lithology, mineralogy, porosity, fluid saturation, and structural complexity of formations at CO₂ storage fields prior to injection. These tools are described in the Site Screening, Site Selection, and Site Characterization for Geologic Storage Projects BPM (NETL, 2016b). The logging tools described below have shown promise for measuring and quantifying CO₂ in pore fluids during and after injection.

PNTs have been proven useful tools for estimating CO₂ saturation in the storage reservoir and shallower strata. A PNT is a small diameter tool that can be run inside tubing (e.g., in an injection or production well) and is not very sensitive to well casing, although measurements can be altered by a change in salinity near the wellbore (e.g., as a result of invasion by drilling or workover fluids). The tool contains a source that emits neutrons into the formation. A detector measures decay times of gamma rays emitted by the capture of these neutrons by reservoir rock and its pore fluids; the data can be processed to estimate fluid saturations; it can also measure gamma rays emitted by inelastic neutron scattering to estimate carbon/oxygen (C/O) ratios. PNTs are sensitive to changes in reservoir fluid composition and can distinguish between brine, oil, and CO₂. In CO₂ monitoring, these tools can be used to quantify CO₂ saturation in strategically placed wellbores, to detect the arrival of a CO₂ plume front, and to detect out-of-zone migration of CO₂. PNT logging may

be conducted in time-lapse mode to record changes in reservoir fluids before, during, and after CO₂ injection. PNT measurements are not sensitive to CO₂ dissolved in water. PNT logs can be run in unperforated boreholes to assess fluids outside of the borehole. If the well is perforated and fluids inside casing change, corrections must be made for the fluids inside the well.

Acoustic logging tools (also known as sonic) are run on wireline and contain a source to produce acoustic waves and a receiver to subsequently measure waveforms, including compressional wave velocity, shear wave velocity, and acoustic wave transit times. Wave forms respond to the lithology, fluid, and confining pressure and other properties of the formation. Sonic logs can be used to monitor changes in pore fluid composition as a CO₂ plume moves past a wellbore because the velocity contrast between water and CO₂ is strong. Sonic sources require large diameter wellbores and good coupling to the formations and so cannot be run through tubing. The casing must be properly cemented or the tube wave along the casing will overwhelm the signals of interest.

Induction logging is a type of resistivity logging that uses EM induction principles to measure the conductivity of a formation. Induction logging is useful for CO₂ monitoring applications because of the large resistivity contrast between CO₂ and water. Rock properties, borehole diameter, bed thickness, and borehole fluids affect resistivity readings. The EM induction technique cannot be applied with conductive metal casing unless the casing interference can be overcome. Recent storage-related EM induction applications have used fiberglass casing with limited success. Ideally, EM induction would be used in time-lapse mode assuming casing issues can be overcome and rock properties are suitable.

In an effort not funded by DOE at the Nagaoka pilot CO₂ injection site in Japan, a complete suite of logging tools in wells with non-conductive casings and relatively fresh water were collected in time-lapse during CO₂ injection and for an extended post-injection period, monitoring CO₂ from 2005 through 2013. The tools were deployed in observation wells located 40 to 120 meters from the injection well, and CO₂ arrival was successfully measured by three independent logging methods. Sonic log measurements showed a large decrease in P-wave velocity; neutron porosity measurements showed an increase in CO₂ saturation; and dual induction logging registered a marked increase

in resistivity (Mito and Xue, 2011). All of these changes are consistent with CO₂ replacing reservoir fluid, as the injected CO₂ plume advanced to the observation wells. The researchers found that P-wave velocity is a better indicator of CO₂ saturation at values below 20 percent CO₂ saturation, while resistivity is more reliable above 20 percent saturation.

Lessons Learned from the Field: Wireline Deployed Well Logging Tools

A time-lapse study using wireline tools was conducted as part of the SECARB Cranfield large-scale field project. The study was successful in providing information for quantifying fluid flow as CO₂ was injected into porous sandstones saturated with saline water. The Schlumberger PNT, known as the Reservoir Saturation Tool (RST), provided the most quantitative information (Butsch et al., 2013) on near-wellbore flow, documenting different saturation profiles in the closely spaced observation wells that are interpreted as evidence of the role of reservoir heterogeneity. Repeat crosswell seismic data collected 10 months after the start of injection also showed a strong systematic change from the pre-injection baseline showing a two-lobed development of fluid change interpreted as the result of substitution of CO₂ for brine. The different geometries of the upper and lower lobes were compatible with the RST results.

Case Study 3.6 describes PCOR's field experience with pulsed neutron tools.

▶ See page 69

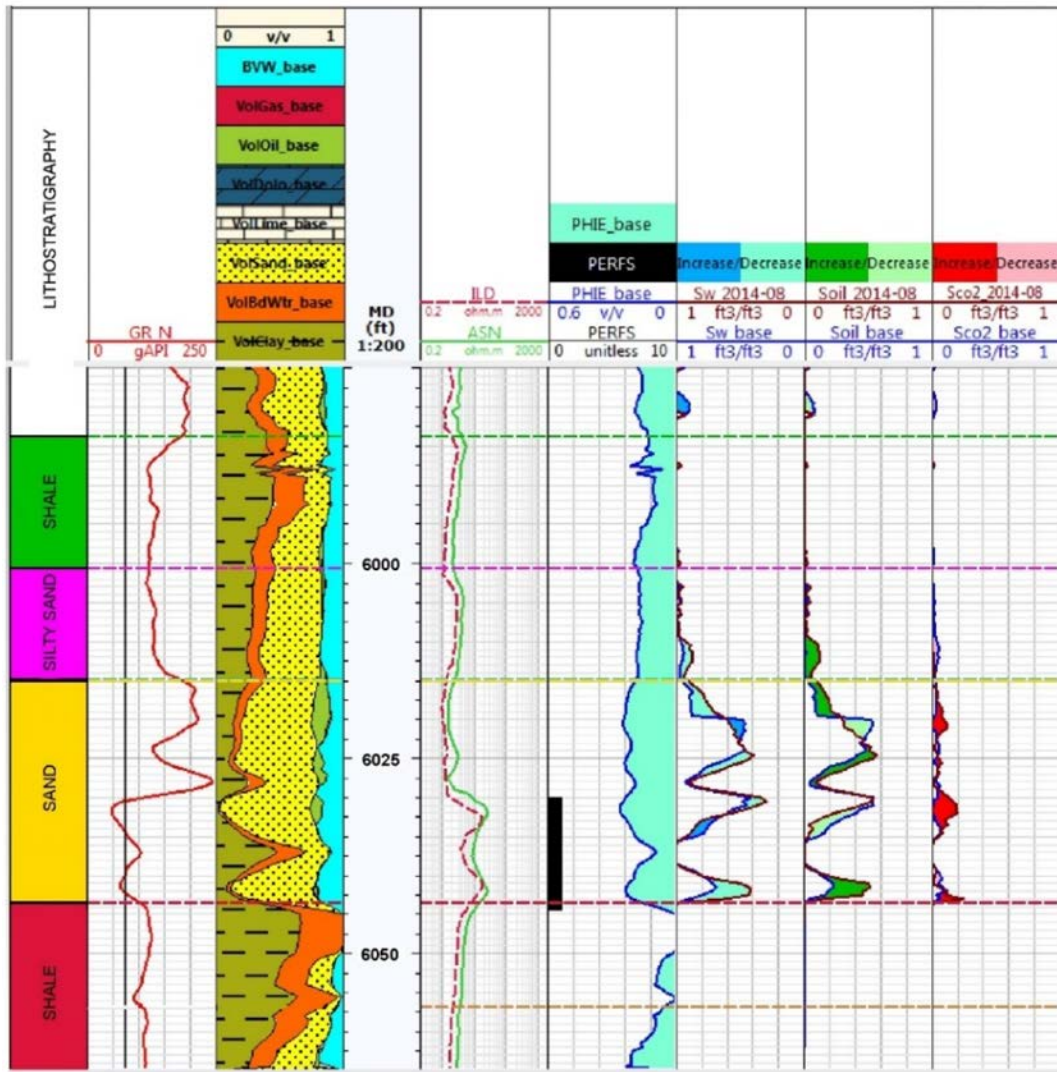

Figure 17: A pulsed-neutron well log displaying (from left to right) facies, gamma ray, baseline sediment and fluid (water/oil) composition, measured depth, resistivity, perforation interval and porosity; water, oil, and CO₂ saturation logs. Color fill in the saturation logs is indicative of relative increase or decrease of the respective fluids from the baseline PNL to the repeat PNL.

Case Study 3.7 summarizes MRCSP's experience with pulsed neutron tools at the Michigan Basin large-scale field project.

[▶ See page 70](#)

The Schlumberger RST was tested at the PCOR Partnership's Northwest McGregor Huff 'n' Puff small-scale field project in North Dakota. The tool was deployed in the 2,450-meter deep Mission Canyon carbonate reservoir (Sorensen et al., 2010). Time-lapse monitoring was achieved by logging the injection well in three stages: (1) prior to injection to establish a baseline;

(2) 72 hours after injection, when the concentration of CO₂ was at its maximum; and (3) 129 days after the well was brought back into production. The results indicate that the CO₂ plume migrated vertically from the injection interval until it encountered an impermeable anhydrite bed, and a portion of the gas migrated and remained at levels below the perforations. These results are consistent with dynamic simulation models, which incorporated a fracture network in the geologic model.

Time-lapse monitoring with a wireline-deployed PNT was carried out at MGSC's Illinois Basin Decatur Project (Finley, 2014). The repeated PNT pulsed neutron saturation logs showed that during the three-year injection period, the

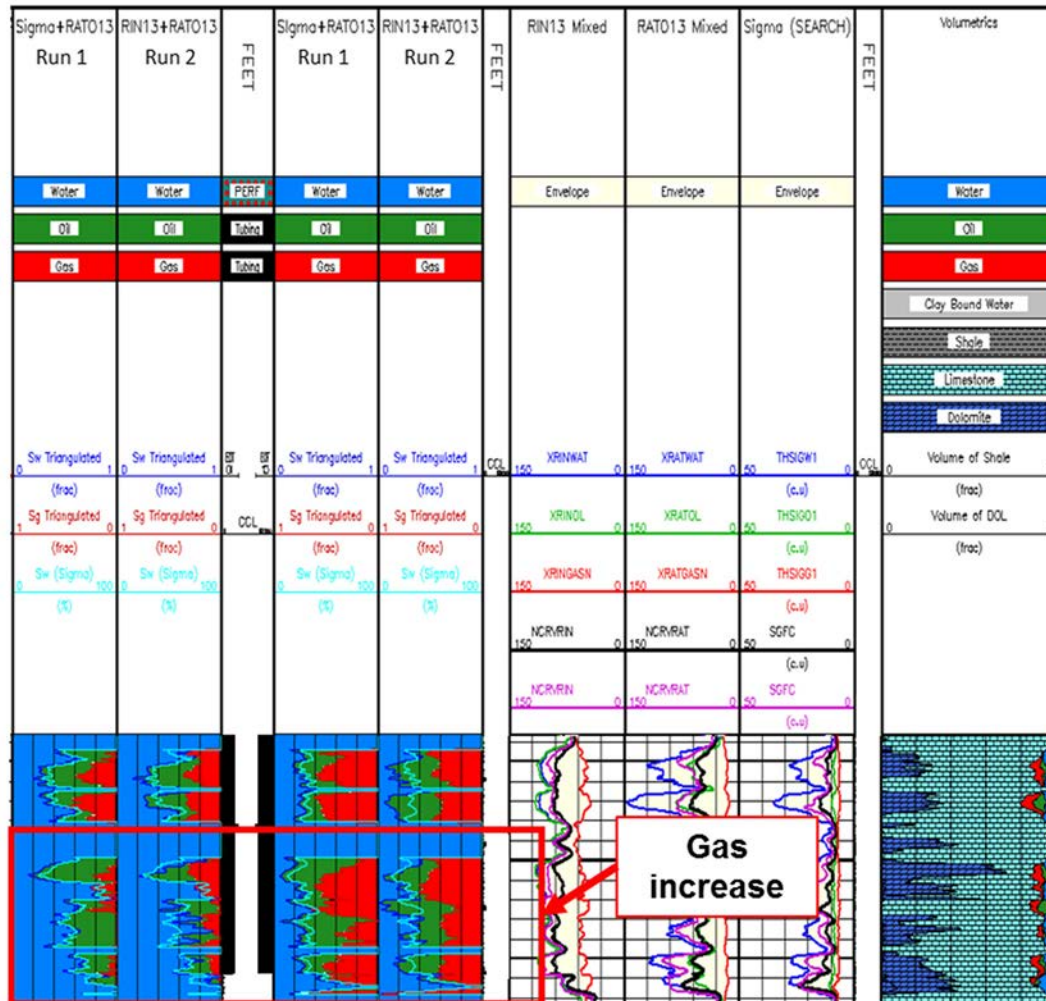

Figure 18: PNL Log Results Exhibits Increase in Gas Saturation, Attributed to Increased Presence of CO₂ (Between Run 1 and 2)
(Percentage of gas is shown in red)

CO₂ was confined to the lower part of the storage reservoir beneath an internal low permeability baffle. The operability of the baffle was assessed by comparison of the pressure increase above and below the baffle in response to injection in the lower parts of the Mt. Simon. The pressure increase was 9.9 bar below the baffle whereas the pressure increase above the baffle was only 1.5 bar.

Current and Ongoing Research: Wireline Deployed Well Logging Tools

In recent years, logging tools and services have been customized for monitoring CO₂ in the subsurface, and commercial vendors are now offering these products and services. Service companies can now recommend

specific logging packages based on prior experience with CO₂ injection projects.

3.3.2.2 WELLBORE MONITORING TOOLS

Wellbore monitoring tools are designed to monitor the condition of the wellbore itself in hydraulically isolating formations. For injection wells, wellbore conditions must be monitored in order to meet EPA standards for proper and safe well operation. External mechanical integrity tests (MITs) are performed to test the integrity of the seals between the cement, the casing, and the storage formation, while internal MITs are used to test the integrity of the casing, tubing, and packers.

The most common wellbore monitoring tools used for CO₂ injection projects are described below and fall into one of three classes: (1) those designed to monitoring wellbore integrity, (2) those designed to monitor wellbore temperature and pressure, and (3) those designed to monitor wellbore-based fluids.

Wellbore Integrity Monitoring Tools

Cement Imaging Tools: Cement imaging tools are used in cased-hole conditions to assess the quality of the cement bond between the borehole rock wall and the casing. Acoustic characteristics are the dominant measurement.

Oxygen-Activation Logs and Temperature Logs: These tools are used to assess external mechanical integrity of the wellbore. Oxygen-activation logs are able to measure the direction and velocity of water movement around the casing. If water is detected moving upward outside of the casing, this may signal a loss of external mechanical integrity. Temperature logs can be used to identify fluid temperature fluctuations that may indicate a poorly sealed rock-casing annulus.

Radioactive Tracer Survey: Radioactive tracers can be used to monitor well and casing performance during injection. A radioactive tracer is released within the casing, and the subsequent gamma ray response is measured through a series of detectors. Movement of the radioactive tracer indicates fluid movement and can reveal leaks through casings or between the casing-rock annulus.

For a more thorough discussion of wellbore integrity evaluation, please see the *Operations for Geologic Storage Projects* BPM.

Wellbore Temperature and Pressure Monitoring Tools

Temperature and Pressure Surveillance: Pressure is a key component in complying with the EPA UIC Class VI Program, both showing that injection pressure is less than the permitted maximum and that the area of pressure elevation is within the prepared and permitted AoR. Most wells are instrumented with pressure and temperature gauges in the wellhead or flow line that may be recorded by a technician or transmitted to a central location. Because CO₂ density varies strongly with temperature and pressure,

wellhead pressure may respond non-linearly with injection zone pressure. Pressure and temperature sensors located near the injection interval reduce uncertainty in measuring this key parameter. The value of the pressure signal can be enhanced by changing injection rates and observing the response of the reservoir. Changes in pressure response can thus be indicative of loss of containment in the well or reservoir. Gauges open to zones above the injection zone may be useful for detecting CO₂ release through the geologic seals. Downhole pressures and temperatures can also be used as inputs for history-matching simulation models to better predict the migration of injected CO₂. Pressure and temperature transducers may be temporarily or semi-permanently placed within the wellbore, or they may be permanently attached to the outside of the casing. Good hydraulic connection between the gauge inlet and the reservoir must be established and maintained.

Distributed Temperature Sensor Systems: Distributed Temperature Sensor (DTS) systems can be used to measure temperature profiles along the length of a wellbore. DTSs are based on fiber-optic technology and have CO₂ monitoring applications similar to those for temperature gauges. DTS systems can operate at depths up to 15,000 meters and can incorporate distributed, point-acoustic, or pressure sensors (Hamling et al., 2011). Any reduction in light transmission caused by absorption or impurities in the optical fiber may lead to measurement errors in DTS systems. Mechanical and chemical exposure can reduce their service life (Jaaskelainen, 2009).

Distributed Thermal Perturbation Sensor: Distributed Thermal Perturbation Sensors (DTPSSs) is a new method designed to estimate the CO₂ saturation in the injection zone by measuring the thermal conductivity of the formation (Freifeld et al., 2009). An increase in CO₂ saturation and a decrease in the brine saturation results in a decrease of the bulk thermal conductivity. DTPS measurements involve installation of an electrical heater with the DTS fiber-optic cables. The heater is energized for a set time period, providing a source of heat along the wellbore. Temperature decay curves after the heater is turned off are inverted to provide estimates of formation thermal conductivity, and thereby CO₂ saturation.

Wellbore-Based Fluids Monitoring Tools

Subsurface Fluid Sampling: Subsurface fluid sampling involves the collection of liquid or gas samples via wells that penetrate a geologic zone of interest. EPA specifies periodic monitoring for geochemical changes above the confining zone(s) that may be a result of CO₂ movement through the confining zones; the injection zone may also be a zone of interest. In addition to migration detection, subsurface samples can provide information on CO₂ arrival at a sample point (known as breakthrough) and geochemical changes taking place in the reservoir due to interaction of the CO₂ with fluids and minerals. Because CO₂ solubility and any equilibrated ionic species are pressure- and temperature-sensitive, the sampling,

analytical, and interpretation techniques applied must deal with the major decrease in pressure and temperature when fluids are transported from reservoir to surface. Various approaches have been used and include sampling with a downhole pressure vessel, isolating the sample with nitrogen drive using a U-tube (Freifeld et al., 2005), or making sufficient downhole and surface measurements to model the downhole conditions. Note that two-phase pore fluids (supercritical CO₂ and brine) are strongly fractionated as they enter the well through perforations and segregate within the well construction, with CO₂ rising. These complexities must be considered during sampling and analysis design and can negate the value of some types of samples for some applications.



Figure 19: U-Tube Downhole Assembly Detail
(Source: Freifeld et al., 2005)

Lessons Learned from the Field: Wellbore Monitoring Tools

The SECARB Validation Phase and Development Phase Cranfield field projects monitored parts of a commercial CO₂ EOR project from the start of injection in July 2008 until 2014. Continuous in-zone pressure measurements in a shut-in observation well open to the storage reservoir were collected. Initiation of injection at wells as much as 3 kilometers from the observation well produced a rapid change in rate of change of pressure response (Hovorka, 2013). Changes in pressure response at closely spaced wells before and during CO₂ injection were used to assess fluid flow properties and develop models, and provide the foundation data against which many other tests were run (Hovorka et al. 2011; Hosseini et al., 2012). Above-zone pressure was also monitored to document the geomechanical response and hydrologic connectivity of the reservoir and the lower part of the confining zone (Tao et al., 2013; Kim et al., 2013). Multiple geometries were tried, including a dual completion (in-zone and above-zone perforations and gauges separated by packers) and above-zone gauges on casing and wireline. Significant difficulty was experienced keeping the gauges in working order and in good communication with the reservoirs and read-out devices. The complex deployments were also difficult to repair. DTS arrays were noisy and had calibration problems at the high temperatures at this site.

At the CO₂SINK project in Ketzin, Germany, the injection well and two observation wells also have permanently installed fiber-optic sensor cables for DTS. The cables were permanently installed behind the casing, allowing access to the entire length of the wellbore, even during technical operations (Giese et al., 2009). The evolution of

temperature in the injection zone, the arrival of CO₂, and the evolution of two-phase pressure and temperature conditions were monitored periodically during 2008 and 2009. It was found that strong transient-temperature effects from injection caused a distortion of the inverted thermal conductivity profiles (Martens et al., 2010).

Subsurface fluid sampling at the SECARB Cranfield large-scale field project was conducted, starting in 2009, to monitor changes associated with CO₂ injection. The aim of the sampling program was to observe geochemical changes that occur as reservoir fluids evolve from a single-phase brine to a two-phase CO₂-brine system (Thordsen et al., 2010, Hovorka et al., 2010). Researchers utilized U-tube, Kuster sampling, and conventional production by gas lift to recover fluids and introduced tracers such as PFTs, noble gases, and SF₆ (Hovorka et al., 2010). Results suggested slow and minimal water-rock interaction in the reservoir, contrasting sharply with results from the Frio pilot project. The relatively minor chemical changes at Cranfield were attributed to the use of fiberglass-lined casing and non-corrosive well components; the predominance of slow-reacting host rocks; and the advance of CO₂, primarily in high-permeability, carbonate-poor, non-reactive, iron chlorite-coated sandstone injection zones (Lu et al., 2012).

A long-term fluid sampling and geochemical analysis program was conducted at the IEAGHG Weyburn-Midale CO₂ Monitoring and Storage Project to determine if dissolution of the host formation rock occurred over time. Fluid chemical measurements and sampling at Weyburn comprised baseline data gathering in 2001 followed by 16 repeat surveys up to 2010 (Johnson and Rostron, 2012). Measured properties included alkalinity, pH, calcium, and DIC stable isotopes. Measurements are all consistent with the effects of early CO₂ dissolution in the formation fluid, followed by the gradual dissolution of carbonate. The direct effects of CO₂ dissolution (e.g. lower pH) were generally dominant, but the slower rate effects of carbonate dissolution became increasingly evident with time, increasing calcium ion content indicative of calcite dissolution. Similar increases in magnesium content indicated progressive dissolution of dolomite. There was significant spatial variation with effects tending to be greatest in the area where most of the CO₂ was injected.

Subsurface fluid sampling has been carried out as part of the monitoring effort at the CO₂CRC Otway Project since injection began in 2008, using an observation well that penetrates the Waarre-C injection zone. U-tube samples have been collected from the gas cap and the

reservoir below the gas-water contact (Sharma et al., 2010; Underschultz et al., 2011). The sampling program was designed to track CO₂ arrival at the observation well and to provide data on the filling of a depleted-gas reservoir, as few other techniques can reliably distinguish between methane and CO₂. Tracers were injected with the supercritical mixture of CO₂ and CH₄ over specified time periods. Breakthrough of the CO₂ at the observation well was observed within the forecast time range of initial fluid flow and reservoir simulation models. The collection of physical fluids played a key role in pinpointing breakthrough. The multilevel U-tubes proved to be robust over an extended timeframe and provided geochemistry data that illuminates the processes by which injected CO₂-rich gas fills a depleted gas reservoir (Boreham et al., 2011).

3.3.2.3 EMERGING WELLBORE TOOLS

Unlike other wellbore tools, these tools are being developed specifically for geologic storage applications and are focused on the subsurface. These monitoring technologies provide direct and indirect information concerning the injection operation and can involve numerical analysis of significant amounts of data.

Modular Borehole Monitoring (MBM) Tool: The MBM is capable of sampling fluids, uses fiber optics to measure pressure and temperature and monitor heat pulse, and has geophones for seismic surveys. This emerging tool consists of a robust borehole monitoring package with a suite of instruments that potentially could meet the needs of a comprehensive well-based monitoring program.

Pressure-Based Inversion and Data Assimilation System (PIDAS): This emerging technology consists of pulsing the injected CO₂ flow rate harmonically and numerically analyzing the corresponding pressure response. The interpretation of the response provides insight concerning storage permanence.

Subsurface Tracer Monitoring: Subsurface tracer monitoring can be used to track the migration of the CO₂ plume in detail between selected wells and assess the phase partitioning of CO₂ in the reservoir. Tracers can be used to augment an out-of-zone migration program. The same tracer program can be designed to serve multiple purposes in the reservoir and near-surface settings. A number of different PFTs and other tracers are available and can be staged or used in combinations to form “cocktails” to differentiate them.

Lessons Learned from the Field: Emerging Wellbore Tools

The Electric Power Research Institute (EPRI) field tested the MBM tool at the SECARB Citronelle field project. For this field test, the MBM included U-tube fluid sampling; permanent quartz pressure/temperature gauges; a short string of 18 geophone pods with locking clamps; and an integrated fiber-optic bundle to facilitate temperature, seismic, and heat-pulse monitoring (Freifeld et al., 2014). The MBM tool functioned as intended for more than two years of operation. The pressure-temperature gauges provided high-quality data. The fiber-optic cable was used for passive DTS, active distributed acoustic sensing (DAS), and active heat-pulse monitoring. The short geophone string provided conventional vertical seismic profile (VSP) data, although some of the 3C (three component) pod channels had wiring failure at installation and did not provide sufficient data. Four walkway VSP surveys were acquired for monitoring with the MBM geophones. The geophone string itself has since been redesigned by the manufacturer to eliminate the problem that led to the loss of channels. The U-tube is currently providing samples as intended from the reservoir that can be used to positively confirm the arrival of CO₂ and tracers.

At Otway, experiments with noble gas tracers were used to make direct measurements of residual trapping. Engineered tracers, used to tag the injected CO₂, were utilized to calculate plume evolution and interactions among constituents such as dissolution of CO₂ into brine and exsolution of CH₄ into the CO₂. Non-reactive tracers can give insight into details of pore-scale flow, since they may be less or more soluble than CO₂ in the pore fluids (LaForce et al., 2014; Paterson et al., 2010).

Columbia University researchers evaluated ¹⁴C as a reactive tracer to assess CO₂ transport in a basaltic storage reservoir (Matter, 2015). Studies were conducted at the CarbFix CO₂ pilot injection site in Iceland. The study evaluated ¹⁴C in combination with trifluoromethyl sulphur pentafluoride (SF₅CF₃) as a conservative tracer to monitor the CO₂ transport in a storage reservoir. During field tests, injected CO₂ was labeled with ¹⁴C. Continuous collection of fluid and gas samples for chemical and tracer analyses was conducted in the injection and monitoring wells. The study found that a high percentage of the injected CO₂ at the CarbFix pilot injection site was mineralized to carbonate minerals, and confirmed that CO₂ mineralization in basaltic rocks is far faster than previously postulated.

Current and Ongoing Research: Emerging Wellbore Tools

The University of Texas at Austin is developing a well testing technology for release detection in carbon storage complexes by developing the theoretical basis and numerical tools required for conducting harmonic pulse tests and results interpretation to assist in the validation of CO₂ storage permanence. The technology is termed Pressure-Based Inversion and Data Assimilation System (PIDAS) for CO₂ release detection (Sun, 2015). Laboratory experiments are designed to validate the numerical tools and theory. Field tests have been conducted at the SECARB Cranfield large-scale field project. Field experiments suggest that pulse testing is a cost-effective, continuous monitoring technique.

Graham, et al. (2015) are improving the ultra-trace detection of SF₆ and PFT mixtures by orders of magnitude to enable cost-effective field tests in large reservoirs. The current highly sensitive GC – Electron Capture Detector (GC-ECD) method of separation and quantification makes SF₆ and PFTs useful conservative tracers for reservoir characterization and flow-path analysis (Graham, et al., 2015). However, even these methods may not be adequate for new and expanded CO₂ storage and EOR or EGR projects. The current generation of field projects is deploying injection and monitoring wells over larger distances and exploring larger reservoirs with complicated flow paths that may change during the injection period. Large quantities of PFTs are required, and samples must be collected frequently over a long period to capture breakthrough peaks in large reservoirs, increasing costs and limiting tracer utility. As long as the background concentration of the tracer is low, applying techniques that are more sensitive can improve data collection and analysis. This project is improving the analytical capabilities using state-of-the-art, commercially available instrumentation and sample concentration methodologies to dramatically improve the limit of detection in gas samples by 100-fold while maintaining or increasing sample throughput, cost efficiency, and the ability to resolve multiple tracers in a single sample.

3.3.2.4 SEISMIC GEOPHYSICAL METHODS

Seismic technologies have benefited from many decades of development, testing, and optimization for the petroleum industry. As a result, these technologies are highly advanced and are used for reservoir characterization, and in some cases reservoir fluid monitoring, in producing oil and gas fields. Since the beginning of the Sleipner project in 1996, seismic imaging techniques and approaches have been carried out and tested successfully for CO₂ monitoring at storage complexes. The challenge is to optimize existing seismic technologies to meet the specific needs of CO₂ injection projects.

Seismic monitoring strategies include surface seismic, borehole seismic, and passive seismic techniques (Figure 20). Surface seismic surveys utilize surface sources to generate downward-propagating elastic waves. These waves travel into the earth and are reflected back to surface at layer boundaries, and velocity and waveform are changed by acoustic impedance properties of the rock-fluid system. Ground motion sensors or geophones record the reflected and refracted waves, and these arrivals are used to develop an image of subsurface geologic structure.

Borehole seismic techniques follow the same principles as surface seismic, but in borehole seismic surveys the receivers, sources, or both are placed in a well (Schlumberger, 2016a). Borehole seismic includes VSP and crosswell seismic. VSPs are generally conducted with the seismic source or array of sources at the land surface and the receiver array placed in a wellbore (Schlumberger, 2016b; Hamling et al., 2013). An array with many closely spaced receivers can produce a high-resolution image near the wellbore (and up to 300 to 600 meters away). Borehole seismic monitoring methods require careful planning to coordinate with other surveys.

- Time-lapse VSPs provide vertical resolution that allows detection of reservoir properties such as fluid saturation changes caused by injection or production activities relatively near the borehole containing the receivers (Daley et al., 2007). Walk-away VSPs and array of receiver wells can be used to monitor the CO₂ plume as it migrates away from the injection well.
- Crosswell seismic is a borehole approach that uses a seismic source located in one well and a receiver array located in an adjacent well. The travel times for each source-receiver pair can be used to create a network of overlapping ray paths, and these are used to make a

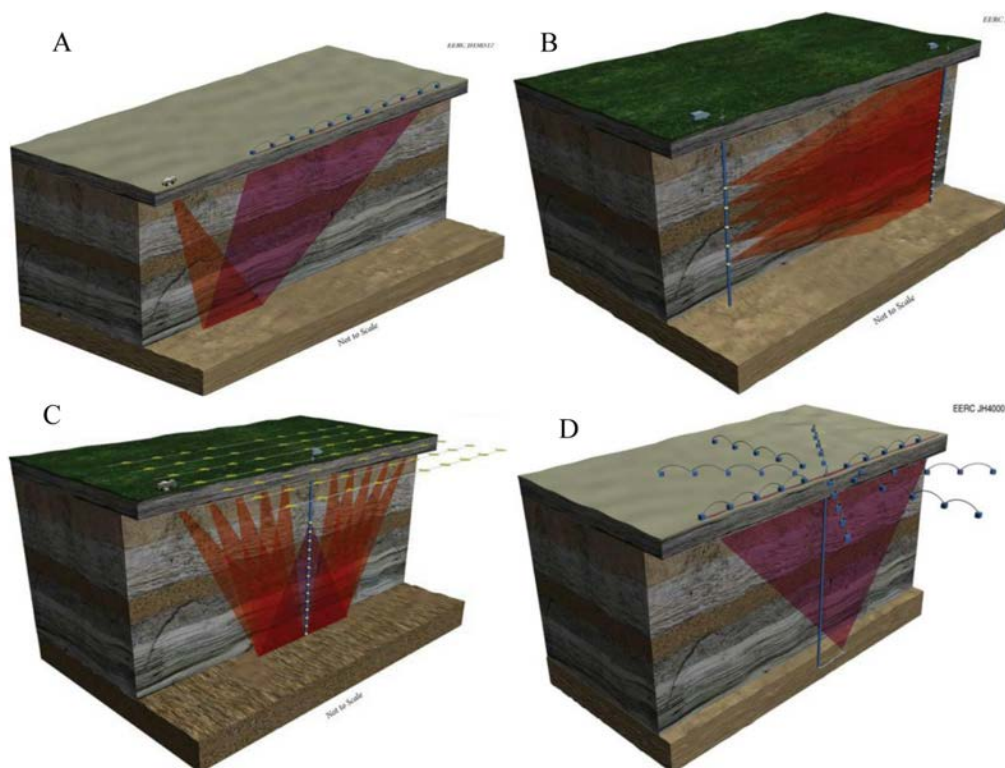

Figure 20: Schematics of Various Seismic Monitoring Techniques: (A) 2-D Surface Seismic, (B) Crosswell Seismic, (C) 3-D VSP, (D) Surface-Based Microseismic

(Source: Hamling et al., 2011)

velocity map (or tomogram) between the wells. Crosswell surveys require wellbore access, and careful planning is required in order to coordinate survey activities with other monitoring activities. At the Frio and SECARB Validation Phase field projects, a method called Continuous Active Source Seismic Monitoring (CASSM) for deploying the receiver array and sources in the injection and monitoring well semi-permanently was successfully tested (Daley et al., 2011); this allowed stacking of data and provided temporal information on plume migration. This technology received an R&D 100 Award in 2015.

- DAS is a relatively recent development in the use of fiber-optic cable for measurement of ground motion. Through Rayleigh scattering, light transmitted down the cable will continuously backscatter or “echo” light so that it can be sensed. Every 10 nanoseconds of time in the optical echo response can be associated with reflections coming from a 1-meter portion of the fiber. By generating a repeated pulse every 100 μ s and continuously processing the returned optical signal, one can, in principle, interrogate each meter of up to 10 km of fiber at a 10-kHz sample rate. Local changes in the optical backscatter, because of changes in the environment of the fiber, can thus become the basis for using the fiber as a continuous array of sensors with nearly continuous sampling in both space and time (Daley et al., 2015).

A seismic reflection survey (3-D survey) can be used for site characterization prior to injection and can serve as the baseline against which repeat surveys can provide time-lapse monitoring (4-D surveys). Changes in reflectivity between surveys can be interpreted as the result of the migration of a CO₂ plume in the subsurface, and in some cases increase in pressure. Two-dimensional seismic

surveys have relatively low collection and processing costs, but the geometry of the area probed may be difficult to resolve. It is important to design the surveys to accomplish monitoring program objectives, while taking into account a number of variables as described below.

Collection of some initial data may have value in optimizing the survey series, in that the source and receiver characteristics, noise, and repeatability can be assessed, optimized, and input into the survey design. Initial data may include sonic logging and VSP surveys. Surface seismic data generally have lower spatial resolution than borehole seismic data and may not image thin zones (Monea et al., 2008). The spatial resolution of a particular surface seismic survey depends on the depth to the target, the frequency content of the source, spacing of sources and receivers, subsurface geologic complexity, and many other site-specific factors (Hamling et al., 2011). Certain geologic features, noise from heavy equipment, or related operations can degrade or attenuate surface seismic data. During time-lapse surveys, source and receiver locations and characteristics, ground-coupling, and other near-surface conditions must be repeated as carefully as possible, and processing must be optimized to remove static error.

Analysis of time-lapse 3-D seismic surveys is a well-established oil industry tool, so developments for geologic storage to some extent track oil industry practice. As illustrated at both Sleipner (Figure 21) and Weyburn, simple time-shift or travel-time analysis is emerging as a particularly useful time-lapse monitoring tool, with the accuracy of travel time picks being enhanced by the statistical power of multi-trace 3-D coverage (Jenkins et al., 2015).

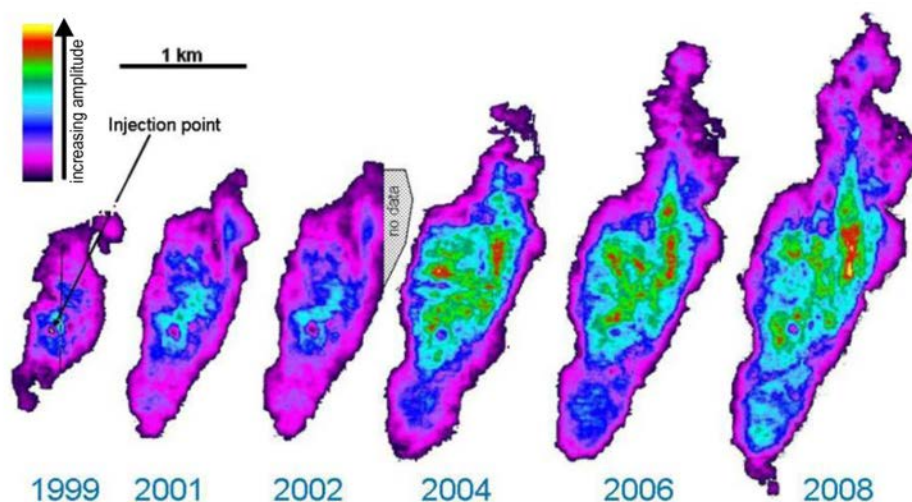

Figure 21: Time-Lapse Seismic Difference Amplitude Maps at Sleipner

(Source: Eiken et al., 2011)

Passive seismic monitoring is a tool used to map seismic events (earthquakes) in the subsurface, and can be designed to detect events with energy too small to be felt at the surface, known as microseismicity. It has been used in the petroleum and geothermal industries to monitor seismicity and microseismicity that has resulted from pressure changes and geomechanical deformation in the reservoir. In geologic storage applications, microseismic monitoring is useful for evaluating the natural seismicity that may be present in a storage complex and for detecting potential induced seismicity resulting from injection.

Passive seismic monitoring prior to injection can be used to establish a baseline of background seismicity. Pre-injection microseismicity monitoring should be coupled with collection of geomechanical properties of the reservoir and surrounding strata, and in-situ stress mapping (which relies on borehole breakout data, drilling-induced fractures, anisotropic acoustic logging, and available focal mechanism solutions) to determine the state of reservoir stress prior to injection.

Passive seismic monitoring during and after injection can be used to detect and locate induced seismic events potentially resulting from CO₂ injection. Induced seismic events may occur if fluid injected into the reservoir raises the pore pressure such that it exceeds the frictional resistance on faults or fractures and triggers slippage. Recording background and induced microseismic events can lead to a better understanding of (1) potential seismic risk in a CO₂ injection site, (2) geomechanical properties of the reservoir, and (3) more accurate mapping of the fluid pressure front representing the advance of the injected CO₂ plume.

Passive seismic surveys are carried out using geophones installed in a wellbore, as isolation from surface noise such as wind and traffic is needed, and good coupling is essential. These geophones are capable of detecting extremely small microseismic events (between -4 and -1 on the moment-magnitude scale). However, natural seismic attenuation in the crust limits the range of monitoring of such small events to several hundred meters from the detectors in most situations.

Because no seismic sources are needed, passive seismic monitoring is well-suited to environmentally sensitive areas. A precise knowledge of the geomechanical properties of the formations, extensive forward modeling, and predictive simulation work is needed to correctly interpret passive seismic data.

Lessons Learned from the Field: Seismic Geophysical Methods

At the SECARB Cranfield large-scale field project, multiple types of seismic geometries were tested: time-lapse 3-D reflection, time-lapse offset VSP, conventional crosswell seismic between three wells, and CASSM. A conventional 3-D reflection survey and one repeat after two years of injection imaged the CO₂; however, some limitations in detection in central parts of the field were noted and tentatively attributed to low concentrations of residual CH₄ in the reservoir (Ditkof et al., 2013; Carter 2014). No out-of-zone CO₂ migration was detected in the time-lapse seismic. The time-lapse offset VSP dataset recorded at the site was hampered by acquisition problems but shows changes in reservoir reflectivity associated with CO₂ displacing brine (Daley et al., 2014). Corridor stacks were used to maximize signal-to-noise ratio (S/N), but imaging spatial variation in reflectivity was not attempted due to the relatively poor S/N. Calculation of time-lapse repeatability, using multiple methods, indicated the need for corroborating information to interpret observed amplitude changes. Seismic modeling established the interpretation of the trough and peak event amplitudes as reflectivity from the top and bottom of the reservoir. In field data, a consistent change was seen at each shot point in both top and base reservoir reflectivity. Importantly, this top/base change gives confidence in an interpretation that these changes arise from within the reservoir, not from bounding formations. Further, the magnitudes of these changes are in agreement with those predicted by modeling. This analysis of top and base amplitude change can be applied to Cranfield's 4-D surface seismic for delineating the CO₂-brine interface.

Conventional crosswell seismic was used to image CO₂ in the interwell region (Ajo-Franklin et al., 2013). Data quality at the Cranfield site was reduced by coherent noise, probably electrical in nature, which obscured low-angle arrivals in the reservoir. Joint inversion of the baseline datasets for each well pair used in the study resulted in a high-resolution view of a segment of the Lower Tuscaloosa Formation referred to as the Tuscaloosa D/E unit, which matched with existing well logs, including openhole sonic logs, and was used in connection with other datasets to evaluate flow in heterogeneous flow fields.

The CASSM survey showed promising early response to pressure changes; however, receiver failure precluded collection of data during the CO₂ injection period.

Several microseismic surveys were deployed with the last and most sensitive six-well array installed by the Research Institute of Innovative Technology for the Earth (RITE) (Takagishi, M. et al., 2014). It is important to note that no microseismicity was detected at the Cranfield site, with a calculated detection threshold of magnitude 0 and pressure elevation locally at about 1,000 psi above hydrostatic.

Case Study 3.8 details PCOR's time lapse seismic survey results from the Bell Creek large-scale field project.

▶ See page 71

Case Study 3.9 describes BSCSP's seismic data collected at the large-scale Kevin Dome field project.

▶ See page 72

The CO₂SINK project at Ketzin, Germany, used time-lapse 3-D and crosswell seismic surveys. The time-lapse 3-D was successful in imaging the CO₂ plume, which migrated westward rather than the expected northward updip direction. This migration was used to modify the reservoir model and produce a history match (Martens et al., 2013).

A series of crosswell seismic surveys were acquired within the framework at various stages of an injection test (Zhang et al., 2012). Crosswell methods were of interest due to their high resolution at this pilot site with closely spaced wells and stratigraphic complexity. The potential of applying crosswell seismic waveform tomography to monitor the CO₂ injection process was explored. Initially, the method was a test on synthetic data having a similar geometry to that of the real data. After successful application on the synthetic data, the method was applied to real data acquired at the Ketzin site. Travel time tomography images of the real data show no observable differences between the surveys. However, seismic waveform tomography images show

significant differences. A number of these differences are artifacts that can probably be attributed to inconsistent receiver coupling between the surveys. However, near the injection zone, below the caprock, a velocity decrease is present that is consistent with that expected from the injection process.

Time-lapse 3-D seismic surveys were not conducted as part of the SECARB Citronelle project, but the team did perform a cross-well survey and constructed a time-lapse image along one transect. The tomograms are of sufficient quality to produce a velocity difference image (Figure 22) showing regions where seismic velocity changed over time. The time-lapse difference image indicates a decrease in seismic velocity in the upper injection zone of as great as 3 percent, suggesting an increase in CO₂ saturation. Negative velocity anomalies are not observed in or above the confining unit, implying no detectable leakage out of the injection zone.

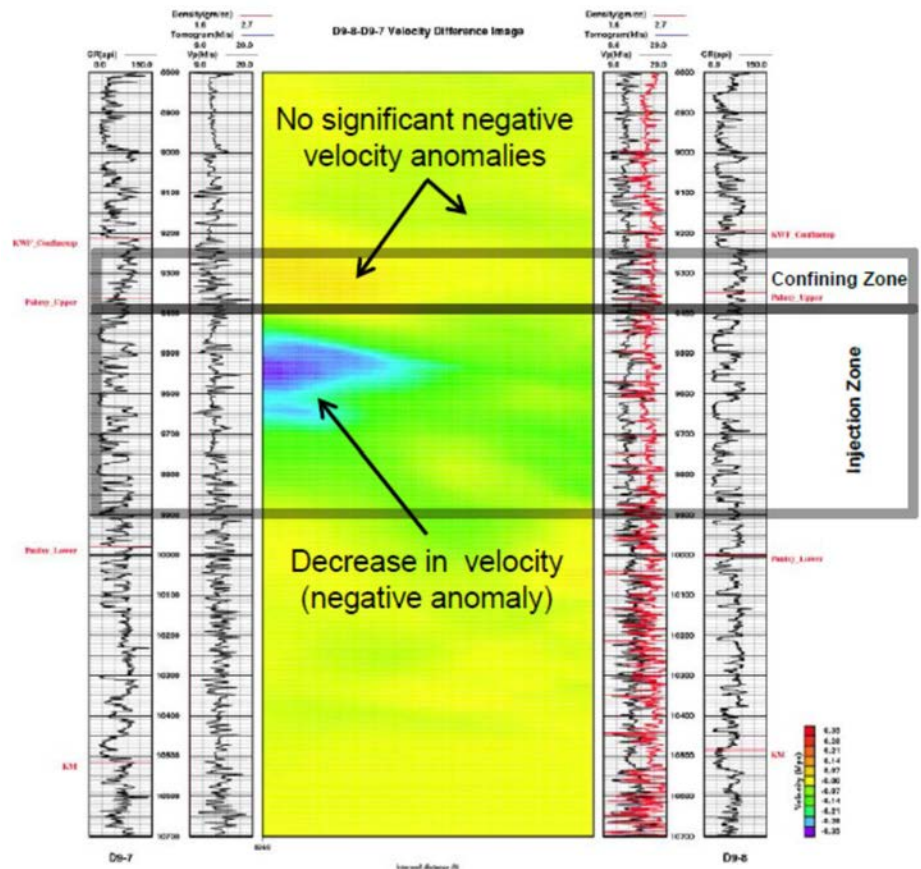

Figure 22. Pixelized difference tomography results without seismic reflection overlay showing positive velocity differences in yellow and negative differences in green and blue

(SECARB Citronelle Project)

Microseismicity associated with injection was measured at MGSC's Illinois Basin Decatur field project starting after injection (Finley, 2014) and has been interpreted as an increasing area of elevated pressure. The microseismicity is located vertically in the basement and pre-Mt. Simon formations, and laterally with lineal features associated with basement topography. Events were not located in sediments above the injection zone.

DAS seismic acquisition is a recent and still-developing technology with many potential advantages. Three sites have been tested for DAS acquisition of borehole seismic data and one included surface seismic data (Daley et al., 2013). Preliminary findings include the following:

- At the SECARB Citronelle field project, the fiber cable was tubing-deployed to 2.9 km in a well coincident with a short string of clamping geophones. The results showed observable seismic energy, mostly tube waves, highlighting the relative low sensitivity of the fluid-coupled fiber and insufficient S/N to see P-waves to 2.9 km, with a standard source effort (4 to 6 sweeps of a vibroseis per shot point).
- At the Otway site, the fiber was again tubing-deployed in a borehole, but a more energetic source and high stack counts (waveforms from 41 weight drops were stacked) generated more useful VSP data. DAS data from the 1,500-meter deep well at Otway could be compared to a previously acquired geophone VSP (with a different source), and approximately 40 to 50 dB decrease in S/N over the entire length was observed. While this is a large difference, improvement in DAS sensitivity is possible, and some partial S/N improvement can be expected with extra source effort. Additionally, the high spatial sampling of 1 meter for DAS provides potential for further noise reduction.
- At Otway, a two-way loop of fiber was run in a surface trench allowing comparison of side-by-side repeatability from separate segments of cable in a surface seismic geometry. The data were found to be quite repeatable. This implies that multiple runs of fiber could be stacked together to improve S/N, and to allow some redundancy in sensors. Furthermore, the surface cable data are shown to be useful for Multichannel Analysis of Surface Waves (MASW), and possibly directional in sensitivity.
- At the Ketzin site, a loop of fiber cable was deployed on casing with some of the cable cemented in place. This provided the best overall data quality, again demonstrating the repeatability of separate segments of fiber cable, and showing the adverse effects of

uncemented zones. Comparison with a conventional geophone VSP demonstrated both the effects of a lack of cement (as expected), and the capability of DAS data to record upgoing VSP reflections over the approximately 700-meter depth of the well.

Taken together, these tests demonstrate a variety of deployment and acquisition possibilities for DAS recording. Increased sensitivity still needs to be achieved.

Current and Ongoing Research: Seismic Methods

The Energy & Environmental Research Center (EERC) of the University of North Dakota is evaluating and demonstrating novel methods for scalable, semi-permanent seismic deployments that can be automated to show where and when a pressure front or CO₂ plume passes a particular subsurface location. This concept uses autonomous node-recording instruments with a remote-controlled downhole and repeatable seismic source. The concept is based on the assumption that the introduction of a small percentage of gas to the reservoir will change the character of the reservoir's seismic reflection in a detectable way. Clever placement of source and receiver allow the use of the seismic method as a yes/no switch to determine when the CO₂ plume or pressure front has moved past a monitored location. Field testing of the method was recently initiated.

The University of Kansas evaluated the effectiveness of a new seismic tool, volumetric curvature (VC), to identify the presence, extent, and impact of paleokarst heterogeneity and faulting structures on geologic CO₂ storage in the Arbuckle Group, a saline carbonate formation in southwestern Kansas (Holubnyak et al., 2014). Existing seismic and well data were reprocessed and analyzed using VC analysis. An integrated geologic model was then developed to indirectly confirm the presence of VC-identified compartments, as well as to estimate CO₂ storage capacity, an optimum CO₂ injection rate, potential CO₂ plume migration, reservoir containment, and CO₂ release risk. A horizontal well was installed to intersect the paleokarst features and confirm that the imaged seismic feature was present.

Case Study 3.10 discusses integration of PNL and seismic monitoring by the PCOR Partnership.

▶ See page 73

3.3.2.5 GRAVITY METHODS

High-precision gravity measurements can be used to detect changes in density caused by CO₂ injection into a storage reservoir. This is because CO₂ is less dense than the formation fluid that it displaces in the reservoir. A change in the vertical gravity gradient may also indicate a change in reservoir pressure (Kerr, 2003). Time-lapse gravity surveys may be used to track the migration and distribution of CO₂ in the subsurface, although the resolution of gravity surveys is much lower than that of seismic surveys. The resolution of a gravity survey can be improved if gravimeters are placed in a wellbore in close proximity to the reservoir of interest, and recent developments of instrumentation suitable for this deployment is substantive progress. Carbon dioxide detection thresholds are site-specific, but, as a general rule, deeper reservoirs are less suitable for gravity monitoring.

Lessons Learned from the Field: Gravity Methods

As part of the SECARB Cranfield project, time-lapse borehole gravity measurements were collected within two multi-use monitoring wells (Dodds et al., 2013). The borehole gravity tests sought to understand the operational and design aspects of data acquisition, and to assess the ability of the tool to detect geology and

injected CO₂. The time-lapse response from CO₂ injection was small but detectable. Instrument drift, depth location repeatability, and the presence of noise were issues that impacted the results of the test. In spite of these issues, the final data shows a significant decrease in density contrast within the reservoir following injection.

Seafloor gravity measurements were also used to constrain the extent of CO₂ dissolution in the injection reservoir at Sleipner (Figure 23) (Alnes et al., 2011). Carbon dioxide injected into deep saline reservoirs can stay in the supercritical phase, dissolve in brine, or react to form solid mineral phases. Carbon dioxide monitoring requires an accounting of CO₂ in supercritical, liquid, and solid phases. The CO₂ density estimated from gravity surveys indicated that the rate of CO₂ dissolution in the brine was less than 1.8 percent per year. This result demonstrates the usefulness of gravity measurements for CO₂ monitoring, i.e., the rate of CO₂ dissolution in brine cannot be detected with time-lapse seismic data, but it was estimated using high-precision gravity surveys.

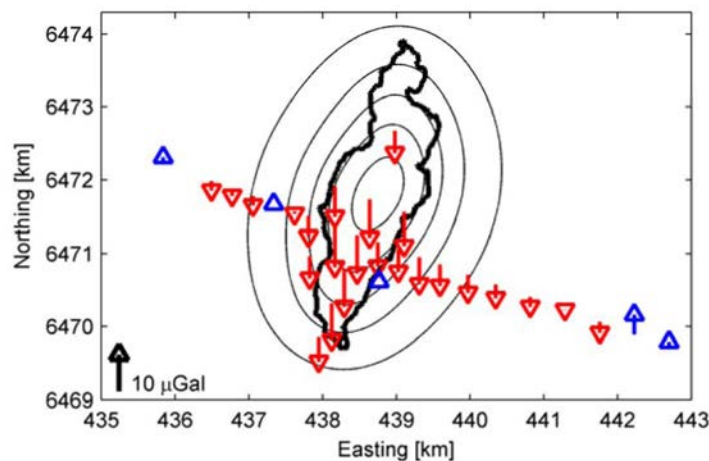

Figure 23: Map of Observed Gravity Changes at Sleipner (2002-2009), Indicating Lowered Gravity Due to CO₂ (Red Arrows)

(Source: Alnes et al., 2011)

Current and Ongoing Research: Gravity Methods

Research addressing gravity methods is focused on field testing of current tools.

3.3.2.6 ELECTRICAL METHODS

Electrical methods can be used to detect the conductivity contrast between CO₂ (less conductive) and saline water (more conductive) in a geologic formation. Specific electrical techniques that have been tested to monitor CO₂ include electrical resistance tomography (ERT), EM tomography, and controlled-source electromagnetic (CSEM) surveys.

ERT and EM can provide a 3-D image of the resistivity distribution of the storage reservoir. In time-lapse mode, these techniques can be used to map the spatial extent of an undissolved CO₂ plume in a saline reservoir to monitor changes in fluid saturation and to track plume migration. In high-salinity brines found at the Nagaoka pilot injection study in Japan, the modest amount of CO₂ dissolved has too small an effect on water/brine resistivity to be measured (Mito and Xue, 2011).

In ERT, electrodes are used to measure the pattern of resistivity in the subsurface. These electrodes can be mounted on the exterior of non-conductive well casing, forming a vertical electrical resistivity array (VERA). This method does not interfere with subsurface monitoring techniques operating within the well casing (Carrigan et al., 2009). ERT may be performed in crosswell or surface-to-downhole configuration, depending on the desired scale of resistivity imaging. Electrical techniques require non-conductive well casings and multiple monitoring wells for best results.

CSEM surveys are also used, mainly in offshore environments, to study variations in the conductivity of the subsurface. Marine CSEM surveys involve towing a high-powered EM source close to the sea floor, and measuring the transmitted fields using widely spaced receivers that are anchored onto the sea floor (Mehta et al., 2005; Pratt, 2006). Low-frequency CSEM monitoring is not sensitive to thin resistive layers, but may provide a suitable tool for large-scale injection monitoring. CSEM surveys have been used successfully to detect hydrocarbons in offshore environments.

Lessons Learned from the Field: Electrical Methods

Several electrical techniques were tested at the CO₂SINK project site in Ketzin, Germany, from 2007 to 2010 to monitor CO₂ injection and plume migration. Crosswell electrical measurements were obtained from a VERA, and surface-to-downhole measurements were obtained using an injection well and two observation wells (Kießling et al., 2010; Schmidt-Hattenberger et al., 2010). Time-lapse, crosswell ERT results indicated a significant resistivity increase in the injection zone of 200 percent over baseline values. The bulk CO₂ saturation was estimated at 50 percent in the injection zone, which lies at an approximate depth of 635 meters (Figure 24). Data resolution was on the order of the electrode separation distance (10 meters) in the vertical array, so that small-scale fingering and zones of low-CO₂ saturation were not detected. Surface-to-downhole ERT data collected at the depth of the injection zone using 16 non-permanent electric dipoles, located 800 and 1,500 meters from each well, indicated preferential migration of CO₂ along the predominant structural trend of the formation.

An experimental crosswell ERT system operated successfully for more than one year obtaining time-lapse electrical resistivity images during the injection of approximately 1 million tonnes of CO₂ at a depth exceeding 3,000 meters at the SECARB Cranfield large-scale field project (X. Yang et al., 2014; Doetsch et al., 2013), representing the deepest application of the method to date. When converted to CO₂ saturation, the resultant images provide information about the movement of the injected CO₂ within a complex geologic formation and the development of the saturation distribution with time. ERT has potential to be considered complementary to seismic; in particular, because once the instrumentation is in place, repeat surveys can be conducted remotely.

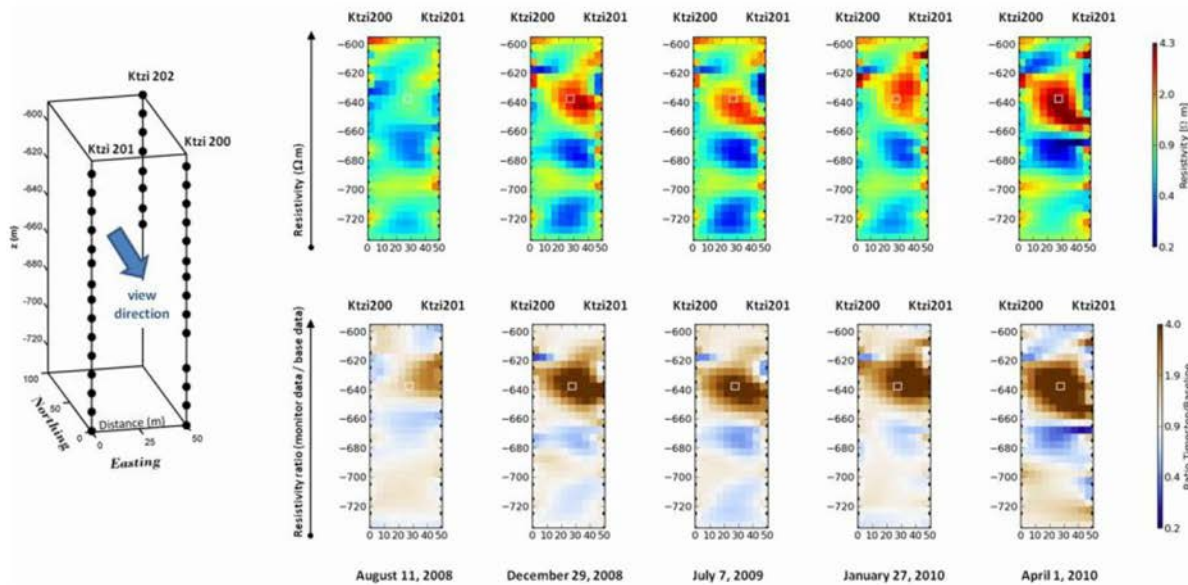

Figure 24: Crosswell Configuration and Time-Lapse Monitoring Results, Indicating Absolute Resistivity Distribution Along Two Observation Wells and Changes in Resistivity Over Base Data at Ketzin

(Source: Schmidt-Hattenberger et al., 2010)

Current and Ongoing Research: Electrical Methods

Multi-Phase Technologies, LLC is developing and testing a robust, cost-effective sensor array for long-term monitoring of CO₂ in storage complexes using CSEM to measure the electrical properties of CO₂ reservoirs. Wireless communication worked well during initial field tests at the injection site in Ketzin, Germany. Long-term operation of the autonomous system will be demonstrated in calendar year 2016 at Ketzin.

Freifeld (2015) is developing continuous, high-frequency (10+ kHz) crosswell and borehole-to-surface electromagnetic tomography. Field tests will involve both configurations at the Carbon Management Canada field research station. The borehole-to-surface surveys will use multiple downhole electrodes below, within and above the injection zone in combination with the surface array of electrodes to collect a data set that will cover the plume boundaries in multiple directions. The crosswell survey places source and receiver tools below, within and above the injection zone at a 5m spacing to provide full tomographic imaging of the plume in 2D. A transmitter frequency of 200 Hz is applied for the tomography which is somewhat low for optimal imaging but as high as can be achieved given that one well is cased with steel.

3.4 RCSP CASE STUDY

CASE STUDY 3.1 — MGSC

MIDWEST GEOLOGICAL SEQUESTRATION CONSORTIUM (MGSC) Autonomous CO₂ monitoring with the GreenLITE System

The Greenhouse gas Laser Imaging Tomography Experiment (GreenLITE) system is a laser absorption spectrometer system, which measures the 2-D spatial distribution of atmospheric CO₂ concentrations. This system is an emerging technology that has the ability to detect and visualize real-time changes in atmospheric CO₂ concentrations and be an automated monitoring technique, which helps reduce environmental monitoring costs.

Before deployment at the Illinois Basin – Decatur Project (IBDP) site, the detection and mapping capability of GreenLITE was first demonstrated at the Zero Emissions Research and Technology (ZERT) field site with controlled release testing over a 4-week period in the fall of 2014. The primary purpose for deploying GreenLITE at the IBDP site was to demonstrate the system's ability to operate autonomously for an extended period of time in a range of environmental conditions.

The configuration of the GreenLITE system at the IBDP project site (Figure below on left) consisted of a pair of laser-based transceivers, thirty retroreflectors, a simple weather station, and a set of cloud-based software tools for data processing, storage, dissemination, and the generation of 2-D maps of CO₂ concentration in near real time. The system was arranged so both transceivers could point to each retroreflector in series and measure the atmospheric CO₂ concentrations along each path, or “chord” in the measurement field.

The installation configuration allowed for the monitoring of an approximately 0.2 km² area, which was largely determined by obstructions and site topography. After pre-operational evaluation, the system continuously collected data from April 1, 2015, until August 17, 2015, in a fully operational and autonomous fashion during the post-injection monitoring phase of IBDP. The monitored area did not include the main injection well, but it did include the IBDP deep monitoring well known as Verification Well 1 (VW1). The figure below on right illustrates the CO₂ concentration distribution near the CO₂ and verification wells measured by the GreenLITE system. Although atmospheric CO₂ concentrations in the study area were elevated at various times, larger CO₂ concentrations could be correlated with wind direction and industrial activity. The system did not detect any sustained and elevated atmospheric CO₂ concentrations at the study site that would suggest leakage.

Based on the performance of the GreenLITE system at IBDP, it has a high potential for value-added integration into a comprehensive commercial scale CCS monitoring, verification and accounting program. The GreenLITE system offers real-time feedback of atmospheric CO₂ concentrations over large areas via a web-based interface, and autonomous operation allows for a cost-effective method to detect CO₂ leakage should it occur.

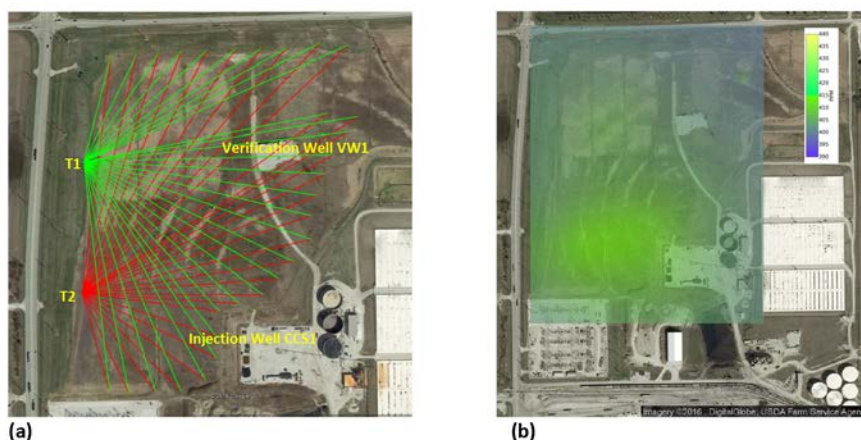

(a) Site layout showing chords from transceivers (T1 and T2) to reflectors. (b) 2-D recreation of the atmospheric CO₂ concentrations collected from the GreenLITE system

CASE STUDY 3.2 — BSCSP

BIG SKY CARBON SEQUESTRATION PARTNERSHIP (BCSP) Differential Absorption Lidar (DIAL)

Differential absorption lidar (DIAL) is a technique that allows spatial mapping of the atmospheric number density of carbon dioxide (CO₂). A prototype instrument employing the DIAL technique was deployed at the BSCSP's Kevin Dome site in north-central Montana. The DIAL instrument utilized a pulsed laser transmitter operating at two wavelengths. The first wavelength is associated with a molecular absorption feature of CO₂ while the second wavelength is minimally affected by the CO₂ absorption feature. The pulse output from the laser transmitter is scattered by atmospheric aerosols, and the backscattered optical signal is collected by the DIAL receiver. The time-of-flight for the reflected light provides the distance from the laser transmitter since the speed of light is well known. If the two wavelengths are spectrally close enough, then the only difference in the return signal results from the CO₂ molecular absorption. The distance-resolved CO₂ number density can then be retrieved utilizing the well-known DIAL equation. By mechanically scanning the DIAL instrument, a spatial map of the CO₂ number density over an area of approximately 4 km² was created at the Kevin Dome site. Concentrations of CO₂ measured with the DIAL instrument compared favorably with measurements made by conventional CO₂ sensors over the study area. An example of data collected at the Big Sky Carbon Sequestration Partnership is shown in the figure below.

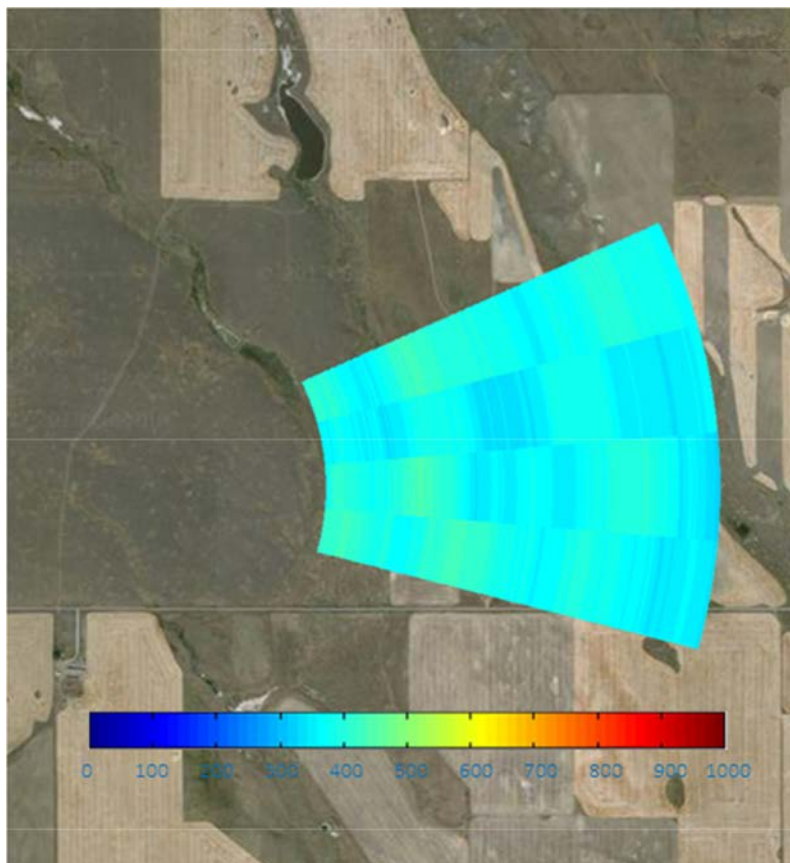

CASE STUDY 3.3 — MGSC

MIDWEST GEOLOGICAL SEQUESTRATION CONSORTIUM (MGSC)

Soil CO₂ Flux Monitoring

Soil CO₂ flux monitoring is a near-surface monitoring technique, which can provide information about the spatial and temporal variability of CO₂ fluxes at the land surface and can be used in a variety of climates and soil conditions (Raich and Schlesinger, 2001). Measurements can be taken continuously or intermittently and can be adapted to measure other gases or collect samples for more detailed compositional analysis as needed. At the MGSC Illinois Basin – Decatur Project site, pre-injection soil CO₂ flux data were compared to data from the injection and post-injection phases of the project to determine if CO₂ injection influenced the site. The data were also used to evaluate monitoring installation types (Locke et al., 2011) and to corroborate results from other monitoring techniques being tested (e.g., laser-based techniques described in Zimmerman et al., 2014 and Levine et al., 2016).

Soil CO₂ flux data were collected at the Illinois Basin – Decatur Project (IBDP) site via the closed-chamber accumulation method along with soil temperature and moisture measurements at each location (Madsen, 2009). The IBDP flux monitoring network consisted of 109 locations where measurements were made weekly as field conditions permitted from 2009 to 2015. Data were quality controlled, statistically evaluated, and used to develop maps of soil CO₂ flux characteristics at the site (see Figure below). Results from the IBDP site did not detect any leakage of CO₂ from the injection reservoir into the near-surface environment.

A goal of the network was to evaluate the effects of soil collar depth and vegetation abundance on flux variability. Multiple installation types were evaluated to determine which type might be the most effective in detecting CO₂ leakage if it occurred. Bare-soil, shallow-depth collars were driven 8 cm into the ground and were prepared with herbicide treatments to minimize surface vegetation in and near the collars. Natural-vegetation, shallow-depth collars were driven 8 cm and are most representative of typical vegetation conditions. Bare-soil, shallow-depth collars had the smallest observed mean flux ($1.9 \mu\text{mol m}^{-2}\text{s}^{-1}$) as compared with the natural-vegetation, shallow-depth collars ($5.0 \mu\text{mol m}^{-2}\text{s}^{-1}$). Therefore, bare collar types would be more sensitive to small CO₂ leak signatures than natural collar types because of higher signal to noise ratios. However, the vegetated soil collars were easier to maintain.

Because of a significant research focus, the flux monitoring program at the IBDP site was more time and resource intensive than would be expected at a commercial scale. Further, soil flux monitoring is expected to be a relatively inefficient method for leakage detection due to the anticipated limited surface expression of CO₂ leaks (Lewicki, Hilley, and Dobeck, 2009; Feitz et al., 2014). Soil CO₂ flux monitoring could be useful to quantify soil flux rates as part of a leakage assessment if a leak were suspected or known to have occurred. For consideration of a soil flux monitoring program at long-term or commercial scale CCS project, site-specific risks, costs, and benefits should be evaluated and soil flux monitoring should be used based on site-specific needs.

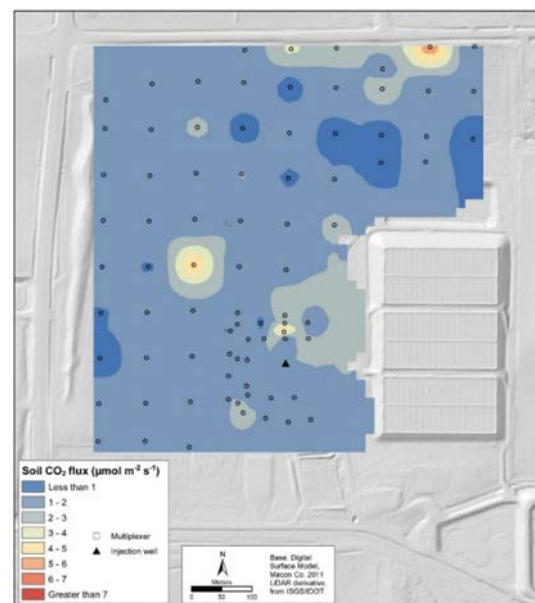

Mean soil CO₂ fluxes before injection at the IBDP site.
(April-June 2011)

CASE STUDY 3.4 — MGSC

MIDWEST GEOLOGICAL SEQUESTRATION CONSORTIUM (MGSC)

Soil Gas Monitoring

Soil gas monitoring is a near-surface technique that can be used to temporally and spatially characterize the soil gas composition and potentially detect CO₂ leakage from a storage reservoir into the soil vadose zone at CCS sites. Data can provide an assurance of safety of CCS operations to the site operator, local landowners, and the public.

Soil gas monitoring was used at the Illinois Basin – Decatur Project (IBDP) site to characterize natural soil gas variability and detect potential leakage of CO₂ in the vadose zone within a 1.5 km² area around the CO₂ injection well (Finley, 2014). Twenty-one permanent soil gas sampling nests were installed on-site, and three off-site reference nests were installed. Samples were collected from three depths (30, 61, 122 cm) at each nest. Fixed gas concentrations (CO₂, N₂, O₂, and light hydrocarbons) and carbon isotope composition ($\delta^{13}\text{C}$) of soil gas samples were monitored during the pre-injection, injection, and post-injection phases of the project. Data from three sampling events before CO₂ injection showed significant temporal and spatial variations of CO₂ concentrations that helped characterize the effects of natural processes that generate or consume CO₂. Differences in the magnitude and variability of CO₂ concentrations observed during the injection and post injection periods were not related to CO₂ injection, but were due to natural processes, biologic respiration, and geochemical reactions. Evaluating the relationships of soil gas components can minimize false positives (i.e., natural processes being incorrectly interpreted as leakage) or false negatives (leakage being masked by natural processes). In addition, $\delta^{13}\text{C}$ analysis showed that the injected CO₂ had a distinct carbon isotopic signature ($\delta^{13}\text{C} = -10.7 \pm 0.4 \text{ ‰}$), compared to the $\delta^{13}\text{C}$ values of the soil gas (-16.0 to -25.6 ‰), further supporting the conclusion that no CO₂ leakage occurred in the vadose zone at the IBDP site. Thus, $\delta^{13}\text{C}$ was an effective natural tracer for leakage detection at the IBDP site.

Overall, six years of soil gas monitoring at the IBDP required extensive manual sampling that was labor intensive. For other sites, the costs and benefits of using this technique should be assessed on a case-by-case basis. If soil gas sampling is used, consideration should be given to how diurnal, seasonal, and annual variability will be evaluated to establish pre-injection conditions. In addition, soil gas sampling programs may be able to focus sampling activities during the injection- and post- injection periods in areas of relatively higher risk (e.g., near injection wells or other potential leakage pathways) during periods with minimal soil biological activities. New autonomous techniques for soil gas monitoring being currently developed could be combined with manual sampling for future large-scale projects (Beaubien et al., 2015; Romanak et al., 2014). If soil gas monitoring is used, each project should evaluate the carbon isotopic composition of the source CO₂ (e.g., from ethanol production, from fossil fuel combustion) to determine if the signatures differ sufficiently for carbon isotopes to be used as an effective natural tracer. In general, soil gas monitoring can be a useful tool in conjunction with other monitoring techniques to confirm a leakage signal and define the extent, magnitude, and source of CO₂ leakage should it occur.

CASE STUDY 3.5 — MGSC

MIDWEST GEOLOGICAL SEQUESTRATION CONSORTIUM (MGSC) Groundwater Compliance Monitoring

Injection activities from CCS projects have the potential to influence groundwater quality if brine or CO₂ migrate from the storage unit into overlying aquifers. Groundwater sampling is a well-established environmental monitoring technique that can be used to temporally and spatially characterize water quality and potentially detect CO₂ leakage in the subsurface. This technique has been used at the Illinois Basin – Decatur Project (IBDP) site to document pre-injection conditions, develop an understanding of the variability of groundwater quality, and verify that project activities are protective of local groundwater resources. The IBDP injected nearly 1 million tonnes of CO₂ into the lower Mt. Simon Sandstone from November 2011 to November 2014 under an Illinois EPA-issued UIC Class I (non-hazardous) permit. Post-injection activities are being conducted under the United States EPA-issued UIC Class VI permit for well CCS1, which became effective on February 15, 2015 (Locke et al., 2017).

The four IBDP shallow regulatory compliance wells were constructed to monitor a thin Pennsylvanian-age sandstone about 140 feet (43 m) below land surface and monitoring began in October 2010. Groundwater samples were collected and analyzed for about 30 constituents during three monitoring periods: pre-injection (14 sampling events), injection (31 sampling events), and post-injection (13 sampling events to date). Water quality data from IBDP sampling has greatly improved the understanding of the physical and chemical properties of local groundwater resources at the site. Eleven compliance parameters were monitored on a quarterly basis for the Illinois EPA Class 1 permit. With the implementation of the US EPA Class VI permit in February 2015, quarterly sampling has been expanded to 28 compliance parameters. Shallow groundwater quality data have shown that neither brine nor injected CO₂ were introduced into the shallow groundwater environment around the IBDP site. In addition, this monitoring program was essential to demonstrate that CO₂ injection has not impacted the shallow groundwater quality, and the observed variability was related to natural groundwater heterogeneity, seasonal groundwater variability, sampling equipment performance, and well installation effects.

In addition to the shallow groundwater sampling, deep fluid sampling has also been an essential part of the IBDP groundwater monitoring program. A verification well (VW1) was designed to allow pressure monitoring and fluid sampling in the Mt. Simon Sandstone (the storage reservoir) as well as the Ironton-Galesville Formation (the first porous and permeable formation above the primary reservoir seal). VW1 was drilled to a depth of 2,214 m (7,264 ft) and the casing was perforated at eight discrete zones in the Mt. Simon Sandstone and two zones in the Ironton-Galesville Formation. Only the upper most zone in the Mt. Simon Sandstone 1723-1724 m (5,654-5,657 ft) and the lower most zone in the Ironton-Galesville 1524-1525 m (5,001-5,004 ft) are used for groundwater compliance monitoring. Since installation of the Westbay multilevel groundwater monitoring and characterization system in 2011, ten fluid sampling events occurred on an annual to semi-annual basis. The Westbay system has provided significant pressure, temperature, and fluid sampling data, but has also had technical challenges with the completion. With an average total dissolved solids concentration of about 200,000 mg/L, brine from the Mt. Simon Sandstone has been very corrosive and required more frequent maintenance of monitoring equipment than originally planned. Additionally, mechanical issues with packers in the well required additional well work to maintain hydraulic isolation between the reservoir and overlying units. The experimental Westbay system has been used effectively to verify that CO₂ has remained within the storage reservoir. It has also helped track the movement of the CO₂ plume, assess well integrity, and evaluate the variability of brine quality vertically and through time in each of the monitoring intervals. The system is at the end of its serviceable life and will be replaced in 2017 when well VW1 undergoes recompletion to ensure its longer-term integrity.

CASE STUDY 3.6 — PCOR

PLAINS CO₂ REDUCTION (PCOR) PARTNERSHIP PCOR Pulsed Neutron Use Within an MVA Program

Understanding near-wellbore fluid or gas saturations provides a mechanism to identify and quantify (if present) vertical migration and/or accumulation of CO₂ throughout the storage complex. Available techniques for monitoring saturation changes throughout the stratigraphic column over a large geographic area are often limited and/or cost prohibitive because of the lack of available access to the subsurface (Braunberger and other, 2014). This is often a challenge for CCS sites associated with EOR operations. To address this challenge, pulse-neutron logging (PNL) allows the use of existing wellbores to monitor saturation changes in the subsurface with minimal impact to field operations (Butsch and others, 2013).

The PNL data may supplement existing datasets, such as well logs (spontaneous potential, resistivity, gamma ray, etc.), seismic data, and geologic core analyses, providing a means to better characterize the geology of both the storage reservoir and overlying strata, detect any fluid migration along wellbores or accumulations in overlying reservoirs, and measure fluid saturations in the reservoir for the simultaneous purposes of containment assurance and sweep efficiency assessment.

As part of its investigation into the associated storage of CO₂ during an active CO₂-EOR project, the PCOR Partnership conducted sigma and inelastic PNL logging campaigns at an EOR site. PNL monitoring consisted of a baseline and repeat campaign for two separate events with passes in the C/O mode, which provided information on the fluid saturation changes within the reservoir interval. Saturation changes were calculated between the baseline and repeat campaign for a respective producer well. An example of a time-lapse PNL repeat pass is indicated in Figure 16 for a logged production well. Color fill is indicative of an increase or decrease in water or oil saturations (in comparison to baseline PNL measurements prior to CO₂ injection). This figure shows preferential pathways for CO₂ flow within the reservoir interval. Decreases in oil saturations correlate well to increases in water saturation and are seen in conjunction with the increase in CO₂ saturation indicating oil mobilization.

Overall, PNL monitoring was beneficial by effectively tracking and monitoring movement of injected CO₂, oil, and gas saturations in the near-wellbore environment, providing the ability to identify unswept oil along a vertical section of the reservoir. This process allows for determining early CO₂ breakthrough and insight into CO₂ accumulations within the reservoir.

CASE STUDY 3.7 — MRCSP

MIDWEST REGIONAL CARBON SEQUESTRATION PARTNERSHIP (MRCSP) Pulsed Neutron Capture

The MRCSP Michigan Basin Project involves assessment of CO₂ EOR and storage in depleted oil fields in the northern fairway of Michigan's Niagaran Reef Trend. A comprehensive field data collection effort is underway to support the characterization, monitoring, and modeling objectives of the program. The individual reefs/oil fields are in various stages of production: pre-EOR, active EOR, and late-stage EOR. Potential storage and EOR production targets include the Brown Niagaran and A-1, A-2 Carbonates. Use of conventional Triple Combo logging in existing wells to evaluate the formation or fluid saturations was problematic because this tool performs only in non-cased boreholes. EOR production involves cased-hole operations; as a result, Pulsed Neutron logging (PNL), which is capable of through-casing evaluation, was implemented to monitor the accumulation and migration of CO₂ in the study reefs.

The MRCSP large-scale field project offered an excellent opportunity to test and validate PNL logging tools under conditions of complex fluid compositions. PNL logging requires a variety of supplemental data in order to produce reliable analyses. Some of the key data needed are fluid densities, salinities, and pressures, which are used to differentiate formation fluids from operation fluids. Cement quality analysis, another key factor in PNL logging, is vital to understanding and characterizing fluid flow and gas accumulation in the reservoir. Participation in multiple logging runs in a number of wells located in the storage reservoirs has enabled substantial progress toward data collection and interpretation of well and formation conditions. Some of these advancements include better logging plans for pre-, active, and post-injection, staging of additional well design, and modeling calibration for fluid saturations. Beyond CO₂ monitoring, PNL tools have also been useful for identifying salt plugged reservoirs. Michigan reefs can have varying degrees of salt plugging in reservoir formations, which plays a role in injectivity and storage capacity. Understanding salt in storage formations will improve characterization and modeling of capacity in potential storage reservoirs. Current and future work will incorporate PNL data into reservoir models to characterize fluid saturation and salt plugging.

See Figure 18 for an example of PNL results.

CASE STUDY 3.8 — PCOR

PLAINS CO₂ REDUCTION (PCOR) PARTNERSHIP Periodic Surface 3-D Seismic Surveys

The PCOR Partnership, led by the Energy & Environmental Research Center (EERC), applies a philosophy of integrating site characterization, modeling and simulation, risk identification, and MVA strategies into an iterative, adaptive management approach. Through the PCOR Partnership's multiple CO₂ storage validation and demonstration projects, this philosophy has been used to determine the effect of large-scale injection of CO₂ into a deep clastic and carbonate reservoir for the purpose of simultaneous CO₂ EOR and associated CO₂ storage.

Periodic (time-lapse) surface 3-D seismic surveys can provide a wealth of information about the geology and status of injection activities of an oil field undergoing CO₂ EOR. Results of time-lapse seismic surveys have been used to improve the site characterization, modeling and simulation, MVA, and risk assessment of the project. The surveys aided in structural interpretation of key horizons, facies, and faults in the storage reservoir. Information on reservoir characteristics between wells guided computations and improved the accuracy of geologic modeling, which then improved predictive simulation history matching.

Gas saturation changes from injected CO₂ is often apparent on time-lapse seismic images, so the images provide a means of tracking CO₂ plume location. For risk assessment, the surveys provide a means of identifying potential faulting or leakage pathways within the reservoir and seal and a way to identify lateral migration beyond field boundaries or into layers above the storage reservoir. Multiple surveys conducted over time provide a means of tracking the progression of the CO₂ plume in the reservoir, which can be used to better manage the injection operations, as well as the timing and location of other monitoring techniques.

The figure at right displays time-lapse results from the PCOR Bell Creek Project.

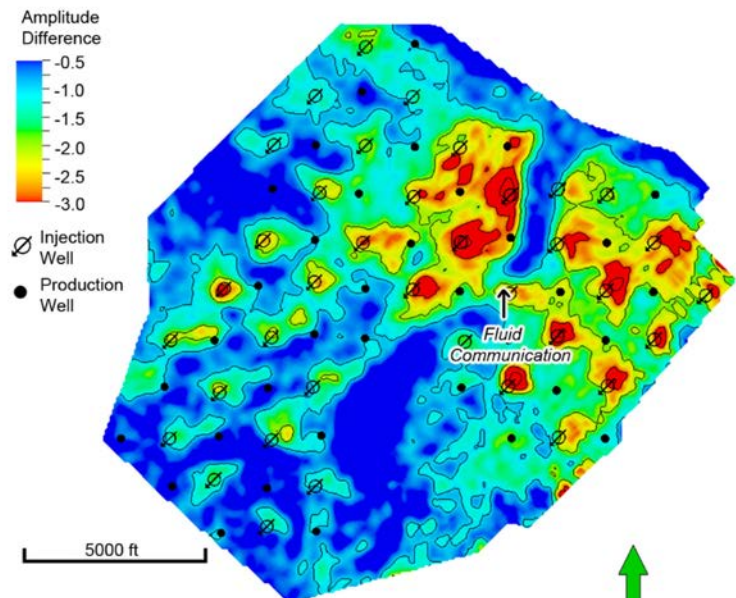

Bell Creek CO₂ EOR project time-lapse (4-D) seismic amplitude difference map of the target injection horizon. The warmer colors indicate regions that have experienced greater change in CO₂ saturation from the baseline seismic survey. The CO₂ response outlines a permeability barrier and fluid communication between the eastern and western portions of the seismic image.

CASE STUDY 3.9 — BSCSP

BIG SKY CARBON SEQUESTRATION PARTNERSHIP (BCSP) 3D 9C Seismic Data for Storage Target and Caprock Characterization

BSCSP has been in the forefront of applying 9 component, 3 dimensional (9C 3D) seismic to improve the characterization of target zones for carbon storage. The Partnership has deployed the technology at its large-scale carbon storage site in northcentral Montana. 9C 3D seismic supplements traditional 3D seismic by recording the entire elastic wavefield using shear-wave seismic sources and multicomponent receivers. When correctly processed and analyzed, the resulting dataset contains both the traditional P-wave seismic data acquired during seismic operations, two shear-mode datasets, and a converted-wave dataset.

These additional datasets contain valuable information about the subsurface not easily derived from conventional P-wave data and allow a joint inversion to be performed that yields high-quality estimates of the P and shear impedances as well as density that can be directly related to rock properties derived from core and well logs. In particular, the density estimate can be used directly for porosity prediction in the storage interval. A 3D geologic model informed by these seismic inputs is much more accurate than one based solely on interpolating sparsely-sampled well data and can be confidently used in flow simulations for large-volume injection programs. An additional benefit of 9C seismic is its unique sensitivity to the presence of natural fractures, which can greatly impact both fluid flow in the subsurface and caprock integrity.

For BSCSP's Kevin Dome Project, 9C 3D seismic was acquired over 37 square miles to image both the natural CO₂ accumulation at the structural top of the dome and the brine leg down dip targeted for sequestration. The seismic survey provided baseline characterization data for the Devonian (Duperow) storage interval as well as the regional primary and secondary caprock layers of the Upper Duperow interbedded tight dolomites and anhydrites and the Potlatch anhydrite layer. After processing and interpretation, the resulting analysis yielded no evidence of large-scale natural fracturing in the Potlatch caprock interval or the underlying Duperow. Integration of the inversion data in the geologic model allowed for more detailed property distribution to characterize regions between sparse well locations at the Kevin Dome greenfield site and resulted in the generation of a more robust model of the geologic subsurface.

CASE STUDY 3.10 — PCOR

PLAINS CO₂ REDUCTION (PCOR) PARTNERSHIP

PCOR PNL and Seismic Monitoring Integration for Risk Reduction

Several different methods are available for monitoring CO₂ migration in an EOR reservoir. Methods can be as simple as noting when a production well produces CO₂ along with oil, natural gas, and water, or be complex geologic modeling that simulates CO₂ plume migration. Pulsed-neutron logs (PNL) and 4-D seismic surveys are two approaches to monitoring CO₂, each tool having specific strengths and limitations. PNLs provide detailed quantitative information on the reservoir fluid saturations; however, they are a well-based measurement with a relatively shallow depth of investigation. Conversely, a time-lapse (4-D) seismic survey images the interwellbore region, but provides a more qualitative assessment of CO₂ saturation, which can also be commingled with a pressure response. When CO₂ is monitored in an EOR project, using several tools to assess the injection zone will yield far more information and can be used to enhance the project's operations.

The PCOR Partnership conducted baseline and repeat PNL campaigns, as well as 4-D seismic (baseline and repeat) acquisition at an EOR site. PNLs were acquired at select injection and production wells with the goals of: (1) quantitatively monitoring and measuring changes in formation fluid saturations near the wellbore with minimal impact to field operations; (2) supplementing legacy log data with modern measures of fluid and gas saturation; (3) providing a gamma ray and porosity log measurement over the entire geologic column to aid in characterizing the caprock and other overlying strata; and (4) providing insight into CO₂-EOR sweep efficiency and containment effectiveness.

4-D seismic surveys consist of a baseline 3-D seismic survey acquired before the start of CO₂ injection, which is followed by a repeat (monitor) 3-D seismic survey sometime after injection has progressed. The difference between the baseline and monitor surveys can provide an image of injected CO₂ within the reservoir and between wells, but the difference can also be affected by pressure differences. 4-D seismic surveys provide a means of monitoring CO₂ migration pathways when the injected volumes and associated saturations are sufficient. Understanding the pathways can inform decisions regarding efficient management of injection and production operations to improve sweep and storage efficiency by identifying channels, geologic boundaries, gas migration pathways, and areas of the reservoir being bypassed by injected CO₂. They also provide a way to monitor strata overlying the reservoir for unintended CO₂ migration, thereby identifying possible locations or means of CO₂ leakage.

Both PNLs and the 4-D seismic data have provided important capabilities in monitoring injected CO₂. The PNLs have provided point data sources for measuring CO₂ saturation. The 4-D seismic program has provided a more qualitative assessment of CO₂ saturation over a geologic volume. With access to both of these datasets, the PCOR Partnership may use the PNLs' measured CO₂ saturations to calibrate and better understand the 4-D seismic difference, in terms of parsing the effects of pressure response and CO₂ saturation in a more quantitative manner. Ultimately, these data increase the ability to better understand the fate of injected CO₂ and ensure safe, successful, long-term storage.

4.0 SUMMARY

The intended audience for this manual includes those involved in the development and implementation of geologic storage projects, governmental agencies, and other non-government organizations. This manual builds on the experiences of the RCSPs with the inclusion of information from other field studies where findings were deemed particularly valuable.

The MVA plan for a given storage project will have a broad scope, covering CO₂ storage containment, operational efficiency, internal quality control, and verification and accounting for regulators and monetizing benefits of GS. MVA is an essential part of ensuring safe, effective, and permanent CO₂ storage in all types of storage complexes. Monitoring technologies can be deployed for atmospheric (surface and above), near-surface, and subsurface applications to ensure that injected CO₂ remains in the storage reservoir and that injection wells and preexisting wells are not prone to unintended CO₂ release. Monitoring is part of operating requirements under the Environmental Protection Agency's (EPA) Underground Injection Control (UIC) Class VI and GHG Reporting Programs to ensure that potable groundwater and ecosystems are protected.

A key lesson and common theme reiterated throughout the manual is that each project site/geology is unique. This means that the development of the MVA plan needs to be designed to address specific site/geology characteristics and should involve an integrated team of experts from multiple technical (e.g., scientific and engineering) and non-technical (e.g., legal, economic, communications) disciplines.

MVA plans should be risk-based, designed to mitigate any potential negative impacts and minimize any uncertainties by iterative application of monitoring technologies and risk analysis. Technologies developed for oil and gas exploration and development provide a good basis for geologic storage MVA plans, but regulations/agreements for geologic storage push technology needs to be more CO₂-specific. Tables 3, 4, and 5 in Chapter 3 describe the various technologies that may be employed to monitor the fate of the CO₂ injected for storage.

APPENDIX 1—RCSP INITIATIVE

In 2003, the DOE launched the RCSP Initiative, by establishing a network of seven RCSPs distributed across the U.S. The overarching objective of this national initiative is to develop the knowledge base, infrastructure, and technology needed to achieve large-scale storage of CO₂ in geologic reservoirs. The RCSPs contribute to this goal through Characterization, Validation, and Development Phase projects in their respective geographic regions.

The seven partnerships are:

- Big Sky Carbon Sequestration Partnership – <http://www.bigskyco2.org>
- Midwest Geological Sequestration Consortium – <http://www.sequestration.org>
- Midwest Regional Carbon Storage Partnership – <http://www.mrcsp.org>
- Plains CO₂ Reduction Partnership – <http://www.undeerc.org/pcor>
- Southeast Regional Carbon Sequestration Partnership – <http://www.secarbon.org>
- Southwest Regional Partnership on Carbon Sequestration – <http://www.southwestcarbonpartnership.org>
- West Coast Regional Carbon Storage Partnership – <http://www.westcarb.org>

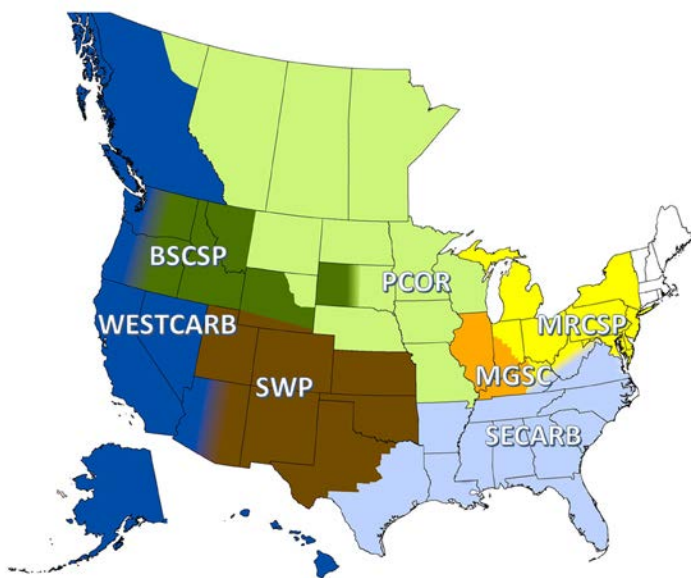

Characterization Phase Projects: The RCSP's Characterization Phase projects began in 2003. These projects focused on collecting data on CO₂ sources and sinks and developing the resources to enable CO₂ storage testing in the field. By the end of this phase, each partnership had succeeded in establishing its own regional network of organizations and individuals working to develop the foundations for CO₂ storage deployment. Characterization Phase projects culminated in the development of a standard, consistent methodology for estimating geologic storage resource, which has been applied in a series of widely acclaimed Carbon Storage Atlases for the United States and portions of Canada¹.

Validation Phase Projects: Validation Phase projects began in 2005, with a shift in focus to small-scale field projects to validate the most promising regional storage opportunities. Nineteen small-scale field projects were successfully completed, resulting in more than 1.0 million metric tons of CO₂ safely injected and monitored. Eight projects were carried out in depleted oil and gas fields, 5 in unmineable coal seams, 5 in clastic and carbonate saline formations, and 1 in basalt. These small-scale tests provide the foundation for larger volume, Development Phase field projects.

Development Phase Field Projects: The Development Phase projects of the RCSP Initiative began in 2008, with large-scale field projects in different geologic settings (Figure 1; Table 1). The aim of these projects is to confirm that CO₂ capture, transportation, injection, and storage can be achieved safely, permanently, and economically. Results will provide a more thorough understanding of plume movement and permanent storage of CO₂ in a variety of geologic storage formations. Experience and knowledge gained from these projects will also help support regulatory development and commercial deployment of geologic storage. The formations being tested are considered regionally significant and are expected to have the potential to store hundreds of years of CO₂ from stationary source emissions. To date, more than 8 million metric tons of CO₂ have been stored in geologic formations via large-scale field projects being developed by the RCSPs.

NATCARB Atlas: Additional information on the large-scale Development Phase field projects can be found in the [DOE/NETL Carbon Storage Atlas, Fifth Edition \(2015\)](#).

REFERENCES

- Ajo-Franklin, J.B., Peterson, J., Doetsch, J., Daley, T.M., 2013, High-resolution characterization of a CO₂ plume using crosswell seismic tomography: Cranfield, MS, USA, *International Journal of Greenhouse Gas Control*, v. 18, pp: 497–509.
- Alnes, H., Eiken, O., Nooner, S., Sasagawa, G., Stenvold, T. and Zumberge, M., 2011, Results from Sleipner gravity monitoring: updated density and temperature distribution of the CO₂ plume, *Energy Procedia*, v. 4, pp: 5504-5511.
- Alonso, J.D. 2015. Real-time in-situ CO₂ Monitoring (RICO₂M) Network for Sensitive Subsurface Areas in CCS. Retrieved from http://www.netl.doe.gov/File%20Library/Events/2015/carbon%20storage/proceedings/08-20_09_3239--JDA--CCS-ProjRevMtng-v1.1.pdf [Accessed June 13, 2016].
- Apps, J.A., Zheng, L., Zhang, Y., Xu, T., Birkholzer, J.T., 2010. Evaluation of potential changes in groundwater quality in response to CO₂ leakage from deep geological storage. *Transport Porous Media* 82, 215–246.
- Apps, J.A., Zheng, L., Spycher, N., Birkholzer, J.T., Kharaka, Y., Thordsen, J., Kakouros, E., and Trautz, R., 2011, Transient changes in shallow groundwater chemistry during the MSU ZERT CO₂ injection experiment, *Energy Procedia*, v. 4, pp: 3231-3238.
- Beaubien, S.E., Ruggiero, L., Annunziatellis, A., Bigi, S., Ciotoli, G., Deiana, P., Graziani, S., Lombardi, S. and Tartarello, M.C., 2015, The Importance of Baseline Surveys of Near-Surface Gas Geochemistry for CCS Monitoring, as Shown from Onshore Case Studies in Northern and Southern Europe, *Oil & Gas Science and Technology-Review, IFP Energies Nouvelles*, v. 70, pp: 615-633.
- Boreham, C., Underschultz, J., Stalker, L., Kirste, D., Freifeld, B., Jenkins, C., Ennis-King, J., 2011, Monitoring of CO₂ storage in a depleted natural gas reservoir: Gas geochemistry from the CO₂CRC Otway Project, Australia, *International Journal of Greenhouse Gas Control*, v. 5, pp: 1039 – 1054.
- Braunberger, J.R., Hamling, J.A., Gorecki, C.D., Steadman, E.N., Harju, J.A., Miller, H.,
- Rawson, J., Walsh, F., Pasternack, E., Rowe, W., and Butsch, R., 2014, Characterization and time-lapse monitoring utilizing pulsed-neutron well logging at an incidental CO₂ storage demonstration: Paper presented at the 12th International Conference on Greenhouse Gas Technologies (GHGT-12), Austin, Texas.
- Butsch, R., Brown, A.L., Bryans, B., Kolb, C., and Hovorka, S., 2013, Integration of well-based subsurface monitoring technologies—lessons learned from SECARB study: *International Journal of Greenhouse Gas Control*, v. 18, p. 409–420.
- Carrigan, C., Ramirez, A.L., Newmark, R.L., Aines, R., Friedmann, S.J., 2009. Application of ERT for tracking CO₂ plume growth and movement at the SECARB Cranfield site, LLNL-CONF-412618: Presented at the 8th Annual Conference on Carbon Capture & Sequestration, Pittsburgh, PA, USA.
- Carroll, S.A., Keating, E., Mansoor, K., Dai, Z., Sun, Y., Trainor-Guitton, W., Brown, C., Bacon, D., 2014, Key factors for determining groundwater impacts due to leakage from geologic carbon sequestration reservoirs. *International Journal of Greenhouse Gas Control*, v. 29, pp: 153–168.
- Carter, R.W., 2014, Fluid Characterization at the Cranfield CO₂ Injection Site: Quantitative Seismic Interpretation from Rock-Physics Modeling and Seismic Inversion. University of Texas at Austin, p. 185.
- Chong, X., Kim, K.J., Li, E., Zhang, Y., Ohodnicki, P.R., Chang, C.H., and Wang, A.X., 2016, Near-infrared absorption gas sensing with metal-organic framework on optical fibers, *Sensors and Actuators B: Chemical*, v. 232, pp: 43-51.

- Chong, X., Kim, K.J., Ohodnicki, P.R., Li, E., Chang, C.H., and Wang, A.X., 2015, Ultrashort Near-Infrared Fiber-Optic Sensors for Carbon Dioxide Detection, *IEEE Sensors Journal*, vol. 15, no. 9, pp: 5327-5332.
- Clegg, S.M., Nowak-Lovato, K., Fessenden-Rahn, J., Martinez, R., Currier, R., Obrey, S., and Huang, L., Surface and Subsurface MVA, 2015, National Energy Technology Laboratory Carbon Storage R&D Project Review Meeting.
- CSA Z741, 2012, IPAC-CO₂ standard for geological storage of carbon dioxide, <http://shop.csa.ca/en/canada/design-for-the-environment/z741-12/inv/27034612012> [Accessed June 13, 2016].
- Daley, T., Ajo-Franklin, J., Doughty, C., 2011, Constraining the reservoir model of an injected CO₂ plume with crosswell CASSM at the Frio-II brine pilot, *International Journal of Greenhouse Gas Control*, v. 5, pp: 1022-1030.
- Daley, T., Freifeld, B., Ajo-Franklin, J., Dou, S., Pevzner, R., Shulakova, V., Kashikar, S., Miller, D., Goetz, J., Henniges, J., and Lueth, S., 2013, Field testing of fiber-optic distributed acoustic sensing (DAS) for subsurface seismic monitoring, *The Leading Edge*, pp: 936 – 942.
- Daley, T., Hendrickson, J., Queen, J., 2014, Monitoring CO₂ Storage at Cranfield, Mississippi with Time-Lapse Offset VSP – Using Integration and Modeling to Reduce Uncertainty, *Energy Procedia* v. 63, pp: 4240 – 4248.
- Daley, T., Miller, D., Dodds, K., Cook, P., Freifeld, B., 2015, Field testing of modular borehole monitoring with simultaneous distributed acoustic sensing and geophone vertical seismic profiles at Citronelle, Alabama, *Geophysical Prospecting*.
- Daley, T.M., Myer, L.R., Peterson, J.E., Majer, E.L., Hoversten, G.M., 2007, Time-lapse crosswell seismic and VSP monitoring of injected CO₂ in a brine aquifer: *Environmental Geology*, v. 54, no. 8, pp: 1657-1665.
- Ditkof, J., Caspari, E., Pevzner, R., Urosevic, M., Meckel, T.A., Hovorka, S.D., 2013, Time-lapse seismic signal analysis for EOR and CCS site, Cranfield field, Mississippi, *Geophysics, Interpretation* 1, T157–T166.
- Dixon, T., Romanak, K., 2015, Improving monitoring protocols for CO₂ geological storage with technical advances in CO₂ attribution monitoring, *International Journal of Greenhouse Gas Control*, v. 41, pp: 29-40.
- DNV, 2010a, CO2QUALSTORE Guideline for selection and qualification of sites and projects for geological storage of CO₂, Det Norske Veritas, DNV Report No.: 2009-1425.
- DNV, 2010b, CO2QUALSTORE Workbook with examples of applications, Det Norske Veritas, DNV Report No.: 2010-0254.
- Dodds, K., Krahenbuhl, R., Reitz, A., Li, Y., Hovorka, S., 2013, Evaluating time-lapse borehole gravity for CO₂ plume detection at SECARB Cranfield. *International Journal of Greenhouse Gas Control*, v. 18, pp: 421–429.
- Doetsch, J., Kowalsky, M.B., Doughty, C., Finsterle, S., Ajo-Franklin, J.B., Carrigan, C.R., Yang, X., Hovorka, S.D., Daley, T.M., 2013, Constraining CO₂ simulations by coupled modeling and inversion of electrical resistance and gas composition data. *International Journal of Greenhouse Gas Control* v. 18, pp: 510–522.
- Eiken, O., Ringrose, P., Hermanrud, C., Nazarian, B. and Torp, T., 2011, Lessons Learned from 14 years of CCS Operations: Sleipner, In Salah and Snøhvit, *Energy Procedia*, v. 4, pp: 5541-5548.
- Elwood, J., Ohodnicki, P.R., 2016, The effect of ionic species on pH dependent response of silica coated optical fibers, *Proceedings SPIE 9386, Micro- and Nanotechnology Sensors, Systems, and Applications VIII*.
- EPA 2016a – “Class VI – Wells used for Geologic Sequestration of CO₂.” *Underground Injection Control (UIC)*, United States Environmental Protection Agency, October 14, 2015. Web. May 6, 2016.

- EPA 2016b – “Subpart RR – Geological Sequestration of Carbon Dioxide.” Greenhouse Gas Reporting Program (GHGRP), United States Environmental Protection Agency, April 29, 2016. Web. May 6, 2016.
- Etheridge D., Lohar, A., Loh, Z., Leuning, R., Spencer, D., Steele, P., Zegelin, S., Allison, C., Krummel, P., Leist, M., and van der Schoot, M., 2010, Atmospheric monitoring of the CO₂CRC Otway Project and lessons for large scale CO₂ storage projects: In Proceedings of the Greenhouse Gas Control Technologies Conference, Amsterdam, The Netherlands.
- European Commission, 2011. Implementation of Directive 2009/31/EC on the Geological Storage of Carbon Dioxide, Guidance Document 2: Characterisation of the Storage Complex, CO₂ Stream Composition, Monitoring and Corrective Measures Available at: http://ec.europa.eu/clima/policies/lowcarbon/ccs/implementation/docs/gd2_en.pdf [Accessed June 13, 2016].
- Finley, R.J., 2014, An overview of the Illinois Basin - Decatur Project, Greenhouse Gas Science and Technology, v. 4, pp: 571–579.
- Feitz, A., Jenkins, C., Schacht, U., McGrath, A., Berko, H., Schroder, I., Noble, R., Kuske, T., George, S., Heath, C., Zegelin, S., Curnow, S., Zhang, H., Sirault, X., Jimenez-Berni, J., Hortle, A., Feitz, A., 2014, An assessment of near surface CO₂ leakage detection techniques under Australian conditions, Energy Procedia, v. 63, pp: 3891-3906.
- Freifeld, B., 2015, http://www.netl.doe.gov/File%20Library/Events/2015/carbon%20storage/proceedings/08-19_18_Freifeld_CCSMR_Task2_CSRD.pdf [Assessed June13, 2016]
- Freifeld, B., Daley, T., Cook, P., Trautz, R., and Dodds, K., 2014, The Modular Borehole Monitoring Program: a research program to optimize well-based monitoring for geologic carbon sequestration, Energy Procedia v. 63, pp: 3500-3515.
- Freifeld, B.M., Daley, T.M., Hovorka, S.D., Henninges, J., Undershultz, J., and Sharma, S., 2009, Recent advances in well-based monitoring of CO₂ sequestration: Energy Procedia, v. 1, no. 1, pp: 2277-2284.
- Freifeld, B.M., Trautz, R.C., Kharaka, Y.K., Phelps, T.J., Myer, L.R., Hovorka, S.D., and Collins, D.J., 2005, The U-tube: A novel system for acquiring borehole fluid samples from a deep geologic CO₂ sequestration experiment: Journal of Geophysical Research, v. 110, B10203, pp: 10.
- Giese, R., Henninges, J., Lüth, S., Morozova, D., Schmidt-Hattenberger, C., Würdemann, H., Zimmer, M., Cosma, C., Juhlin, C., and CO₂SINK Group, 2009. Monitoring at the CO₂SINK site: A concept integrating geophysics, geochemistry and microbiology: Energy Procedia, v. 1, no. 1, pp: 2251-2259.
- Graham, D.E., Pfiffner, S.M., Phelps, T.J., Kharaka, Y.K., Thordsen, J.J., and Cole, D.R., 2015, Monitoring of Geological CO₂ Sequestration Using Isotopes and Perfluorocarbon Tracers, Retrieved from https://www.netl.doe.gov/File%20Library/Events/2015/carbon%20storage/proceedings/08-19_23_Graham_20150818.pdf [Accessed June 13, 2016].
- Hamling, J., Gorecki, C., Klapperich, R., Saini, D., Steadman, E., 2013, Overview of the Bell Creek combined CO₂ storage and CO₂ enhanced oil recovery project, Energy Procedia, v. 37, pp: 6402-6411.
- Hamling, J.A., Gorecki, C.D., Steadman, E.N., and Harju, J.A., 2011, Subtask 1.3 - Evaluation of geophysical technologies for application to CCS: Final topical report prepared for National Energy Technology Laboratory under Cooperative Agreement No. DE-FC26-08NT43291, Energy and Environmental Research Center, Grand Forks, ND.
- Hnottavange-Telleen, K., 2013, Common Themes in Risk Evaluation Among Eight Geosequestration Projects, Energy Procedia, v. 37, pp: 2794-2801.

- Hnottavange-Telleen, K., 2014, Risk management at the Illinois Basin – Decatur Project: A FEPs-based approach, *Greenhouse Gas Science and Technology*, v. 4, pp: 604-616.
- Holubnyak, Y., Rush, J., and Watney, W., 2014, Evaluation with Dynamic Simulations of the Volumetric Curvature Tool for Modelling Reservoir Compartments and Leakage Pathways in the Arbuckle Saline Aquifer, *Energy Procedia*, v. 63, pp: 3544-3552.
- Hortle, A., de Caritat, P., Stalvies, C., Jenkins, C., 2010, Groundwater monitoring at the Otway Project site, Australia: In *Proceedings of the Greenhouse Gas Control Technologies Conference*, Amsterdam, The Netherlands.
- Hosseini, S.A., Nicot, J.-P., 2012, Scoping analysis of brine extraction/re-injection for enhanced CO₂ storage, *Greenhouse Gas Science and Technology*, v. 2, pp: 172-184.
- Hovorka, S., Daley, D., 2010, Update five years post-injection Frio brine pilot: Presented at the IEAGHG Monitoring Network meeting, May 7, 2010, Natchez, MS, USA.
- Hovorka, S., Meckel, T., Trevino, R., 2013, Monitoring a large volume injection at Cranfield, Mississippi—project design and major conclusions, *International Journal of Greenhouse Gas Control* v. 18, pp: 345-360.
- Hovorka, S.D., Meckel, T.A., Trevino, R.H., Lu, J., Nicot, J.-P., Choi, J.-W., Freeman, D., Cook, P., Daley, T.M., Ajo-Franklin, J.B., Freifeild, B.M., Doughty, C., Carrigan, C.R., Brecque, D.L., Kharaka, Y.K., Thordsen, J.J., Phelps, T.J., Yang, C., Romanak, K.D., Zhang, T., Holt, R.M., Lindler, J.S., Butsch, R.J., 2011, Monitoring a large volume CO₂ injection: year two results from SECARB project at Denbury’s Cranfield, Mississippi, USA, *Energy Procedia* v. 4, pp: 3478-3485.
- Humphries, S.D., 2008, Carbon Dioxide Sequestration Monitoring and Verification Via Laser Based Detection System in the 2 micrometer Band: Montana State University Doctoral Dissertation.
- IEAGHG, 2009, A review of the international state of the art in risk assessment guidelines and proposed terminology for use in CO₂ geological storage, 2009/TR7, December 2009.
- Jain, J., McIntyre, D., Krishna, A., Dikshit, V., Goueguel, C., Yu-Yueh, F., Singh, J., 2011, Development of a Laser-Induced Breakdown Spectroscopy (LIBS) Sensor for Detecting CO₂ Leak from Carbon Sequestration Injection Formations: Presented at the Annual Carbon Capture Conference, Pittsburgh, USA.
- Jaaskelainen, M., 2009, Distributed temperature sensing (DTS) in Geothermal Energy Applications SensorTran, Inc.
- Jenkins, C., Chadwick, A., Hovorka, S., 2015, The state of the art in monitoring and verification—Ten years on, *International Journal of Greenhouse Gas Control*, v. 40, pp: 312-349.
- Johnson, J.W., Rostron, B.J., 2012, Geochemical monitoring. In: Hitchon, B. (Ed.), *Best Practices for Validating CO₂ Geological Storage – Observations and Guidance from the IEAGHG Weyburn – Midale CO₂ Monitoring Project*, Geoscience Publishing.
- Jones, D.G., Lister, T.R., Smith, D.J., West, J.M., Coombs, P., Gadalia, A., Brach, M., Annunziatellis, A., Lombardi, S., 2010, In Salah Gas CO₂ Storage JIP: Surface gas and biological monitoring: In *Proceedings of the Greenhouse Gas Control Technologies Conference*, Amsterdam, The Netherlands.
- Karegar, M., Dixon, T., Malservisi, R., Yang, Q., Hosseini, S., Hovorka, S., 2015, GPS-based monitoring of surface deformation associated with CO₂ injection at an enhanced oil recovery site, *International Journal of Greenhouse Gas Control*, v. 41, pp: 116-126.

- Kerr, H., 2003, CO₂ Capture Project - An integrated, collaborative technology development project for next-generation CO₂ separation, capture and geologic sequestration -Semi-annual report for February - July 2003. Available at: http://www.fischer-tropsch.org/DOE/DOE_reports/41145/41145-1/41145-1_toc.htm [Accessed June 13, 2016].
- Kharaka, Y.K., Thordsen, J.J., Kakouros, E., Ambats, G., Herkelrath, W.N., Beers, S.R., Birkholzer, J.T., Apps, J.A., Spycher, N.F., Zheng, L., Trautz, R.C., Rauch, H.W., and Gullickson, K.S., 2010, Changes in the chemistry of shallow groundwater related to the 2008 injection of CO₂ at the ZERT field site, Bozeman, Montana, *Environmental Earth Sciences*, v. 60, no. 2, pp: 273-284.
- Kießling, D., Schmidt-Hattenberger, C., Schuett, H., Schilling F., Krueger, K., Schoebel, B., Danckward, E., Kummerow, J. and the CO₂SINK Group, 2010, Geoelectrical methods for monitoring geological CO₂ storage: First results from cross-hole and surface-downhole measurements from the CO₂SINK test site at Ketzin (Germany): *International Journal of Greenhouse Gas Control*, v.4, no. 5, pp: 816-826.
- Kim, K.J., Chong, X., Kreider, P.B., Ma, G., Ohodnicki, P.R., Baltrus, J.P., Wang, A.X., 2015, Plasmonics-enhanced metal-organic framework nanoporous films for highly sensitive near-infrared absorption, *Journal of Materials Chemistry C*, vol. 3 no.12, pp: 2763-2767.
- Kim, S., Hosseini, S., 2013, Above-zone pressure monitoring and geomechanical analyses for a field-scale CO₂ injection project in Cranfield, MS, *Greenhouse Gas Science and Technology*, v. 4, pp: 81-98.
- Klusman, R., 2005, Baseline studies of surface gas exchange and soil-gas composition in preparation for CO₂ sequestration research: Teapot Dome, Wyoming, *AAPG Bulletin*, v. 89, no. 8, pp: 981-1003.
- LaForce, T., Ennis-King, J., Boreham, C., Paterson, L., 2014, Residual CO₂ saturation estimate using noble gas tracers in a single-well field test: the CO₂CRC Otway project, *International Journal of Greenhouse Gas Control*, v. 26.
- Levine, Z.H., Pintar, A.L., Dobler, J.T., Blume N., Braun, M., Zaccheo, T.S., and Pernini, T.G., 2016, The Detection of Carbon Dioxide Leaks Using Quasi-tomographic Laser Absorption Spectroscopy Measurements in Variable Wind. *Atmospheric Measurement Techniques Discussions* v. 8.11, pp: 12297-12327.
- Lewicki, J.L., Hilley, G.E., Dobeck, L., and Spangler, L. 2009, Dynamics of CO₂ Fluxes and Concentrations during a Shallow Subsurface CO₂ Release, *Environmental Earth Sciences*, v. 60.2, pp: 285-297.
- Lewicki, J.L. and Hilley, G.E., 2009, Eddy covariance mapping and quantification of surface CO₂ leakage fluxes: *Geophysical Research Letters*, v. 36, L21802, doi:10.1029/2009GL040775.
- Lewicki, J.L. and Hilley, G.E., 2012, Eddy covariance network design for mapping and quantification of surface CO₂ leakage fluxes, *International Journal of Greenhouse Gas Control*, v. 7, pp: 137-144.
- Liu, N., 2015, Development of a CO₂ Chemical Sensor for Downhole CO₂ Monitoring in Carbon Sequestration, Retrieved from http://www.netl.doe.gov/File%20Library/Events/2016/crosscutting-ree/track-b-041916/Presentation_20160419_0830B_FE0009878_NMT.pdf [Accessed June 13, 2016].
- Locke, R.A., Greenberg, S.E., Jagucki, P., Krapac, I.G., and Shao, H., 2017 (in press), Regulatory uncertainty and its effects on monitoring activities of a major demonstration project: The Illinois Basin-Decatur Project case, *Energy Procedia*.
- Locke, R.A., Krapac I.G., Lewicki J.L., and Curtis-Robinson, E., 2011, Characterizing Near-surface CO₂ Conditions Before Injection – Perspectives from a CCS Project in the Illinois Basin, USA, *Energy Procedia* v. 4, pp: 3306-3313.
- Lu, J., Kharaka, Y., Thordsen, J.J., Horita, J., Karamalidis, A., Hakala, J.A., Ambats, G., Cole, D.R., Phelps, T.J., Manning, M.A., Cook, P.J., and Hovorka, S.D., 2012, CO₂-rock-brine interactions in Lower Tuscaloosa Formation at Cranfield CO₂ sequestration site, Mississippi, U.S.A.: *Chemical Geology*, v. 291, pp: 269-277.

- Madsen, R., Xu, L., Claassen, B., and McDermitt, D, 2009, Surface Monitoring Method for Carbon Capture and Storage Projects, *Energy Procedia*, v. 1.1, pp: 2161-2168.
- Male, E.J., Pickles, W.L., Silver, E.A., Hoffmann, G.D., Lewicki, J., Apple, M., Repasky, K., and Burton, E.A., 2010, Using hyperspectral plant signatures for CO₂ leak detection during the 2008 ZERT CO₂ sequestration field experiment in Bozeman, Montana: *Environmental Earth Sciences*, v.60, no.2, pp: 251-261.
- Martens, S., Liebscher, A., Moller, F., Henniges, J., Kempka, T., Luth, S., Norden, B., Prevedel, B., Szizybalski, A., Zimmer, M., Kuhn, M., Ketzin, G., 2013, CO₂ storage at the Ketzin pilot site, Germany: Fourth year of injection, monitoring, modelling and verification, *Energy Procedia* v. 37, pp: 6434-6443.
- Martens, S., Liebscher, A., Möller, F., Würdemann, H., Schilling, F., and Kühn, M., 2010, Progress report on the first European on-shore CO₂ storage site at Ketzin (Germany) – Second year of injection: In *Proceedings of the Greenhouse Gas Control Technologies Conference*, Amsterdam, The Netherlands.
- Mathieson, A., Midgely, J., Wright, I., Saoula, N., and Ringrose, P., 2011, In Salah CO₂ Storage JIP: CO₂ sequestration monitoring and verification technologies applied at Krechba, Algeria, *Energy Procedia*, v. 4, pp: 3596-3603.
- Matter, Juerg, 2015, Radiocarbon as a Reactive Tracer for Tracking Permanent CO₂ Storage in Basaltic Rocks, DOE Final Report, <http://www.osti.gov/scitech/biblio/1238341-radiocarbon-reactive-tracer-tracking-permanent-co2-storage-basaltic-rocks> [Accessed June 13, 2016].
- Mehta, K., Nabighian, M. & Li, Y., 2005, Controlled source electromagnetic (CSEM) technique for detection and delineation of hydrocarbon reservoirs: an evaluation: In *2005 SEG Technical Program Expanded Abstracts*, v. 24, pp: 546-549.
- Meier, B., and Sharma, S., 2015, Using stable carbon isotopes to track potential leakage of carbon dioxide: Example from an enhanced coal bed methane recovery site in West Virginia, USA, *International Journal of Greenhouse Gas Control*, vol. 41, pp: 107-115.
- Mito, S., and Xue, X., 2011, Post-Injection Monitoring of Stored CO₂ at the Nagaoka Pilot Site: 5 Years Time-Lapse Well Logging Results, *Energia Procedia* v. 4, pp: 3284-3289.
- Monea, M., Knudsen, R., Worth, K., Chalaturnyk, R., White, D., Wilson, M., Plasynski, S. McIlvried, H.G., and Srivastava, R.D., 2008, Considerations for monitoring, mitigation, and verification for geologic storage of CO₂: American Geophysical Union (AGU) Monograph, *Science and Technology of Carbon Sequestration*, Sundquist, E.T. and McPherson, B., Eds, pp: 303-316.
- Myers, M., Stalker, L., Pejicic, B., Ross, A., 2013, Tracers—Past, present and future applications in CO₂ geosequestration, *Applied Geochemistry*, v. 30, pp: 125-135.
- NETL (National Energy Technology Laboratory), 2016a, Best Practices for Risk Management and Simulation for Geologic Storage Projects.
- NETL (National Energy Technology Laboratory), 2016b, Best Practices for Site Screening, Site Selection, and Site Characterization for Geologic Storage Projects.
- Oldenburg, C. M., Nicot, J.-P., Jordan, P.D., Zhang, Y., Pan, L., Houseworth, J.E., Meckel, T., Carr, D.L., and Bryant, S.L., 2015, Chapter 32: Health, safety, and environmental risk assessment of geologic carbon sequestration: Overview of the certification framework, example application, and selected special studies 2010-2014, in Karl F. Gerdes, ed., *Carbon dioxide capture for storage in deep geologic formations—Results from the CO₂ Capture Project, Volume 4: CCS Technology Development and Demonstration Results (2009-2014)*: UK, CPL Press, pp: 569-592.

- Paterson, L., Boreham, C., Bunch, M., Ennis-King, J., Freifeld, B., Haese, R., Jenkins, C., Raab, M., Singh, R., Stalker, L., 2010, The CO₂CRC Otway Stage 2b Residual Saturation and Dissolution Test, Milestone report to ANLEC.
- Pearce, J., Blackford, J., Beaubien, S.E., Foekema, E., Gemeni, V., Gwosdz, S., Jones, D.G., Kirk, K., Lions, J., Metcalfe, R., Moni, C., Smith, K., Steven, M.D., West, J.M., Ziogou, F., 2014a, RISCS - A Guide to potential impacts of leakage from CO₂ storage. British Geological Survey.
- Pearce, J., Jones, D., Blackford, J., Beaubien, S., Foekema, E., Gemeni, V., Kirk, K., Lions, J., Metcalfe, R., Moni, C., Smith, K., Stevens, M., West, J., Ziogou, F., 2014b, A guide for assessing the potential impacts on ecosystems of leakage from CO₂ storage sites Energy Procedia, v. 63, pp: 3242-3252.
- Pekney, N., Wells, A., Diehl, J., McNeil, M., Lesko, N., Armstrong, J., Ference, R., 2011, Atmospheric Monitoring of a Perfluorocarbon Tracer at the ZERT Center 2010 Experiments in Bozeman, Montana, USA: Presented at the Annual Carbon Capture Conference, Pittsburgh, USA.
- Pekney, N., Wells, A., Diehl, J., McNeil, M., Lesko, N., Armstrong, J., Ference, R., 2012, Atmospheric monitoring of a perfluorocarbon tracer at the 2009 ZERT Center Experiment, Atmospheric Environment, v. 47, pp: 124-132.
- Pratt, D., 2006, Special Report: Controlled source electromagnetic imaging offers synergies with seismic, well-log data - Oil & Gas Journal. Oil & Gas Journal: Available at: <http://www.ogj.com/index/article-display.articles.oil-gas-journal.volume-104.issue-37.exploration-development.special-report-controlled-source-electromagnetic-imaging-offers-synergies-with-seismic-well-log-data.html> [Accessed June 13, 2016].
- Raich, J.W., and W.H. Schlesinger, 2001, Global Annual Soil Respiration Data (Raich and Schlesinger 1992). Data set. Available on-line [http://daac.ornl.gov] from Oak Ridge National Laboratory Distributed Active Archive Center, Oak Ridge, Tennessee, U.S.A. HYPERLINK "http://dx.doi.org/10.3334/ORNLDAAAC/622" doi:10.3334/ORNLDAAAC/622.
- Repasky, K.S., Carlsten, J.L., Soukup, B., and Wicks, G., 2012, Development of a 1 X N Fiber Optic Sensor Array for Carbon Sequestration Site Monitoring: U.S. Department of Energy Carbon Storage R&D Project Review Meeting, Pittsburgh, PA.
- Riding, J.B., Rochelle, C.A., 2005, The IEA Weyburn CO₂ Monitoring and Storage Project. Final report of the European research team, British Geological Survey Research Report RR/05/03, p: 54.
- Ringrose, P., Atbi, M., Mason, D., Espinassous, M., Myhrer, Ø., Iding, M., Mathieson, A., and Wright, I., 2009, Plume development around well KB-502 at the In Salah CO₂ Storage Site: First Break, v. 27, pp: 85-89.
- Romanak, K., Sherk, G., Hovorka, S., Yang, C., 2013, Assessment of Alleged CO₂ Leakage at the Kerr Farm using a Simple Process-based Soil Gas Technique: Implications for Carbon Capture, Utilization, and Storage (CCUS) Monitoring, Energy Procedia, v. 37, pp: 4242-4248.
- Romanak, K.D., Womack, G.L., Bomse, D.S., 2014, Field test of in situ sensor technology for process-based soil gas monitoring, Energy Procedia, v. 63, pp: 4027-4030.
- Romanak, K.D., Yang, C., and Hovorka, S., 2010a, Targeted soil-gas methodologies for monitoring an engineered, plugged, and abandoned well site, Cranfield, Mississippi, GCCC Digital Publication Series #10-05: presented at the 9th Annual Conference on Carbon Capture & Sequestration, Pittsburgh, PA.
- Romanak, K.D., Smyth, R.C., Yang, C., and Hovorka, S., 2010b, Detection of anthropogenic CO₂ in dilute groundwater: field observations and geochemical modeling of the Dockum aquifer at the SACROC oilfield, West Texas, USA, GCCC Digital Publication Series #10-06: presented at the 9th Annual Conference on Carbon Capture & Sequestration, Pittsburgh, PA, May 10-13, 2010.

- Romanak, K.D., Smyth, R.C., Yang, C., Hovorka, S.D., Nicot, J.-P., and Lu, J., 2008, Executive summary: Recent results of the SACROC groundwater geochemistry study: submitted to Federal Requirements Under the Underground Injection Control (UIC) Program for Carbon Dioxide (CO₂) Geologic Sequestration (GS) Wells – Notice of Data Availability and Request for Comment (EPA-HQ-OW-2008-0390-0297). GCCC Digital Publication Series #08-22, pp: 1-5.
- Rouse, J.H., Shaw, J.A., Lawrence, R.L., Lewicki, J.L., Dobeck, L.M., Repasky, K.S., and Spangler, L.H., 2010, Multi-spectral imaging of vegetation for detecting CO₂ leaking from underground: *Environmental Earth Sciences*, v.60, no.2, pp: 313-323.
- Schacht U., Regan, M., Boreham, C., Sharma, S., 2010, CO₂CRC Otway Project – Soil gas baseline and assurance monitoring 2007-2010: In *Proceedings of the Greenhouse Gas Control Technologies Conference*, Amsterdam, The Netherlands.
- Schlumberger, 2016a, Oilfield Glossary: Term 'borehole seismic data'. Available at: http://www.glossary.oilfield.slb.com/Terms/b/borehole_seismic_data.aspx [Accessed June 13, 2016].
- Schlumberger, 2016b, Oilfield Glossary: Term 'vertical seismic profile'. Available at: http://www.glossary.oilfield.slb.com/Terms/v/vertical_seismic_profile.aspx [Accessed June 13, 2016].
- Schmidt-Hattenberger C., Bergmann, P., Kießling, D., Krüger, K., Rücker, C., Schütt, H., and Ketzin Group, 2010, Application of a vertical electrical resistivity array (VERA) for monitoring CO₂ migration at the Ketzin site: First performance evaluation: In *Proceedings of the Greenhouse Gas Control Technologies Conference*, Amsterdam, The Netherlands.
- Sharma, S., Cook, P., Jenkins, C., Steeper, T., Lees, M., and Ranasinghe, N., 2010, The CO₂CRC Otway Project: Leveraging experience and exploiting new opportunities at Australia's first CCS project site: In *Proceedings of the Greenhouse Gas Control Technologies Conference*, Amsterdam, The Netherlands.
- Shell, 2010, QUEST carbon capture and storage project: Measurement, monitoring and verification plan, Shell Canada Ltd., <http://s04.static-shell.com/content/dam/shell-new/local/country/can/downloads/pdf/aboutshell/our-business/oil-sands/quest/02-quest-vol-1-appxammvplan.pdf>, [Accessed June 13, 2016].
- Sorensen, J.A., Schmidt, D.D., Knudsen, D.J., Smith, S.A., Gorecki, C.D., Steadman, E.N., and Harju, J.A., 2010, Northwest McGregor field CO₂ huff 'n' puff: A case study of the application of field monitoring and modeling techniques for CO₂ prediction and accounting: In *Proceedings of the Greenhouse Gas Control Technologies Conference*, Amsterdam, The Netherlands.
- Soukup, B., Repasky, K., Carlsten, J., 2014, Wicks, G., Field demonstration of a 1x4 fiber sensor array for subsurface carbon dioxide monitoring for carbon sequestration, *Journal of Applied Remote Sensing*, v 8, pp: 083699-1-083699-12.
- Spangler, L.H., Dobeck, L.M., Repasky, K.S., Nehrir, A.R., Humphries, S.D., Barr, J.L., Keith, C.J., Shaw, J.A., Rouse, J.H., Cunningham, A.B., Benson, S.M., Oldenburg, C.M., Lewicki, J.L., Wells, A.W., Diehl, J.R., Strazisar, B.R., Fessenden, J.E., Rahn, T.A., Amonette, J.E., Barr, J.L., Pickles, W.L., Jacobson, J.D., Silver, E.A., Male, E.J., Rauch, H.W., Gullickson, K.S., Trautz, R., Kharaka, Y., Birkholzer, J., Wielopolski, L., 2010, A shallow subsurface controlled release facility in Bozeman, Montana, USA, for testing near-surface CO₂ detection techniques and transport models, *Environmental Earth Science*, v. 60, pp: 227-239.
- Sun, A., 2015, Pressure-Based Inversion and Data Assimilation System for CO₂ Leakage Detection. Retrieved from http://www.netl.doe.gov/File%20Library/Events/2015/carbon%20storage/proceedings/08-19_09_alexsun_pidas2015.pdf [Accessed June 13, 2016].
- Takagishi, M., Hashimoto, T., Horikawa, S., Kusunose, K., Xue, Z., Hovorka, S., 2014, Microseismic Monitoring at the Large-Scale CO₂ Injection Site, Cranfield, MS, U.S.A., *Energy Procedia*, v. 63, pp: 4411-4417.

- Tao, Q., Bryant, S.L., Meckel, T.A., 2013, Modeling above-zone measurements of pressure and temperature for monitoring CCS sites, *International Journal of Greenhouse Gas Control*, v. 18, pp: 523-530.
- Thordsen, J.J., Kharaka, Y.K., Ambats, G., Manning, M.A., Cole, D.R., Phelps, T.J., Horita, J., and Lu, J., 2010, Gas-brine-rock interactions following CO₂ injection into the Tuscaloosa sandstone: Results from SECARB Phase III at Cranfield, MS: Presented at the 2010 GSA Denver Annual Meeting, Denver, CO, USA.
- Trautz, Robert C., Pugh, John D., Varadharajan, Charuleka, Zheng, Liange, Bianchi, Marco, Nico, Peter S., Spycher, Nicolas F., Newell, Dennis L., Esposito, Richard A., Wu, Yuxin, Dafflon, Baptiste, Hubbard, Susan S., and Birkholzer, Jens T., 2012, Effect of Dissolved CO₂ on a Shallow Groundwater System: A Controlled Release Field Experiment, *Environmental Science and Technology*, ACS Publications.
- Underschultz, J., Boreham, C., Dance, T., Stalker, L., Freifeld, B., Kirste, D., Ennis-King, J., 2011, CO₂ storage in a depleted gas field: An overview of the CO₂CRC Otway Project and initial results, *International Journal of Greenhouse Gas Control*, v. 5, pp: 922-932.
- Vesper, D.J. and Edenborn, H.M., 2012, Determination of free CO₂ in emergent groundwaters using a commercial beverage carbonation meter, *Journal of Hydrology*, 438-439, pp: 148-155.
- Wang, C., Su, X., Brown, T.D., Ohodnicki, P.R., 2015a, Novel sensing materials for harsh environment subsurface pH sensing applications, *Proceedings SPIE 9840, Fiber Optics Sensors and Applications XII*.
- Wang, C., Ohodnicki, P.R., Su, X., Keller, M., Brown, T.D., and Baltrus, J.P., 2015b, Novel silica surface charge density mediated control of the optical properties of embedded optically active materials and its application for fiber optic pH sensing at elevated temperatures, *Nanoscale* vol. 7, no. 6, pp: 2527-2535.
- Wilson, P., Feitz, A., Jenkins, C., Berko, H., Loh, Z., Luhar, A., Hibbend, M., Spencer, D., Etheridge, D., 2014, Sensitivity of CO₂ leak detection using a single atmospheric station, *Energy Procedia*, v. 63, pp: 3907-3914.
- Wilson, T.H., Wells, A., Peters, D., Mioduchowski, A., Martinez, G., Koperna, G., Akwari, B., Heath, J., 2012, Fracture and 3D seismic interpretations of the Fruitland Formation and cover strata: Implications for CO₂ retention and tracer movement, San Juan Basin Pilot test, *International Journal of Coal Geology*, doi:10.1016/j.coal.2012.02.007.
- Wimmer, B.T., Krapac, I.G., Locke, R., Iranmanesh, A., 2010, Applying monitoring, verification, and accounting techniques to a real-world, enhanced oil recovery operational CO₂ leak: In *Proceedings of the Greenhouse Gas Control Technologies Conference*, Amsterdam, The Netherlands.
- Yang, C., Delgado-Alonso, J., Hovorka, S., Mickler, P., Trevino, R., Phillip, S., 2014a, *Energy Procedia*, v. 63, pp: 4209-4215.
- Yang, C., Hovorka, S.D., Treviño, R.H., Delgado-Alonso, J., 2015a. Integrated Framework for Assessing Impacts of CO₂ Leakage on Groundwater Quality and Monitoring-Network Efficiency: Case Study at a CO₂ Enhanced Oil Recovery Site. *Environmental Science Technology*, doi: 10.1021/acs.est.1025b01574.
- Yang, C., Hovorka, S.D., Young, M.H., Trevino, R.H., 2014b. Geochemical sensitivity to CO₂ leakage: detection in potable aquifers at carbon sequestration sites. *Greenhouse Gases: Science and Technology*, v. 4, pp: 384-399.
- Yang, C., Mickler, P.J., Reedy, R., Scanlon, B.R., Romanak, K.D., Nicot, J.-P., Hovorka, S.D., Trevino, R.H., Larson, T., 2013a, Single-well push-pull test for assessing potential impacts of CO₂ leakage on groundwater quality in a shallow Gulf Coast aquifer in Cranfield, Mississippi. *International Journal of Greenhouse Gas Control*, v. 18, pp: 375-387.

- Yang, C., Romanak, K., Holt, R.M., Lindner, J., Smith, L., Trevino, R., Roecker, F., Xia, Y., Rickerts, J., Horvorka, S., 2012, Large Volume of CO₂ Injection at the Cranfield, Early Field Test of the SECARB Phase III: Near-Surface Monitoring (CMTC 151428). Carbon Management Technology Conference, Orlando, Florida, USA, p. 10.
- Yang, C., Romanak, K., Hovorka, S., Holt, R.M., Lindner, J., Trevino, R., 2013b. Near-surface monitoring of large-volume CO₂ injection at Cranfield: early field test of SECARB Phase III. SPE Journal v: 18, pp: 486-494.
- Yang, C., Romanak, K., Hovorka, S., Trevino, R., 2013c, Modeling CO₂ release experiment in the shallow subsurface and sensitivity analysis. Environmental & Engineering Geoscience v. 19, no. 3, pp: 207-220.
- Yang, C., Treviño, R.H., Hovorka, S.D., Delgado-Alonso, J., 2015b. Semi-analytical approach to reactive transport of CO₂ leakage into aquifers at carbon sequestration sites. Greenhouse Gases Science and Technology, pp: 1-16.
- Yang, X, Chen, X., Carrigan, C., Ramirez, A., 2014, Uncertainty quantification of CO₂ saturation estimated from electrical resistance tomography data at the Cranfield site, International Journal of Greenhouse Gas Control, v. 27, pp: 59-68.
- Zhang, F., Juhlin, C., Cosma, C., Tryggvason, A., Pratt, R., 2012, Cross-well seismic waveform tomography for monitoring CO₂ injection: a case study from the Ketzin Site, Germany, International Geophysical Journal, v. 189, pp: 629-646.
- Zimmerman, J., Locke, R.A. II, Blakley, C., Frish, M., Ladere, M., and Wainner, R., 2014, Tunable Diode Laser Absorption Spectrometers for CO₂ Wellhead and Pipeline Leakage Monitoring: Experiences from Prototype Testing at the Illinois Basin – Decatur Project, USA, Energy Procedia, v. 63, pp: 4083-4094.

ACKNOWLEDGMENTS

This report presents information prepared by the MVA Working Group as part of the RCSP Initiative. Lead authors and contributing authors include the following:

Big Sky Carbon Sequestration Partnership

Lee Spangler

Midwest Geologic Sequestration Consortium

Randy Locke and Hongbo Shao

Midwest Regional Carbon Sequestration Partnership

Lydia Cumming, Jackie Gerst, and Neeraj Gupta

Plains CO₂ Reduction Partnership

Kyle Glazewski, Kerryanne Leroux, Scott Ayash, and John Hamling

Southeast Regional Carbon Sequestration Partnership

Susan Hovorka

Southwest Regional Partnership on Carbon Sequestration

Ning Liu and Rich Esser

NETL Support to MVA Working Group

David Wildman and Charles Pruss

The authors wish to acknowledge the excellent guidance, contributions, and cooperation of NETL staff, particularly:

NETL Federal Project Managers

Bill Aljoe and Kylee Rice

NETL Portfolio Manager

Traci Rodosta

CONTACTS

Please contact the following individuals for more information about DOE's Carbon Storage Program:

NATIONAL ENERGY TECHNOLOGY LABORATORY

CARBON STORAGE PROGRAM PORTFOLIO MANAGER

Traci Rodosta
304-285-1345
traci.rodosta@netl.doe.gov

CARBON STORAGE TEAM SUPERVISOR

Kanwal Mahajan
304-285-4965
kanwal.mahajan@netl.doe.gov

BEST PRACTICE MANUAL LEAD

Kylee Rice
304-285-4445
mary.rice@netl.doe.gov

U.S. DEPARTMENT OF ENERGY OFFICE OF FOSSIL ENERGY

Darin Damiani
304-285-4398
darin.damiani@hq.doe.gov



1450 Queen Avenue SW
Albany, OR 97321-2198
541-967-5892

3610 Collins Ferry Road
P.O. Box 880
Morgantown, WV 26507-0880
304-285-4764

626 Cochrans Mill Road
P.O. Box 10940
Pittsburgh, PA 15236-0940
412-386-4687

Program staff are also
located in Houston, Texas
and Anchorage, Alaska

CUSTOMER SERVICE

1-800-553-7681

www.NETL.DOE.gov



Scan this
with your
smartphone to
link to NETL's
website.